

MCSe 7.3-21

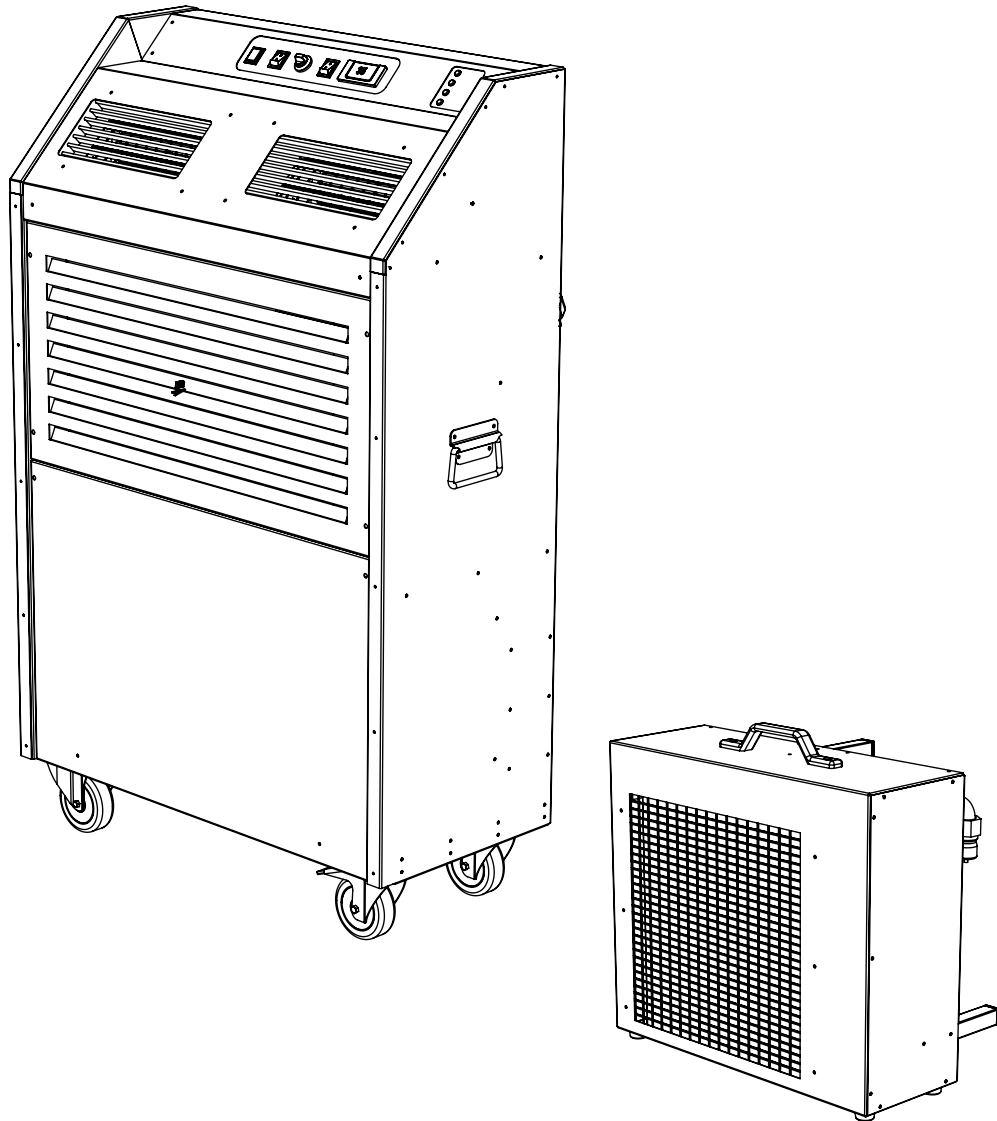

MCSe 7.3-21B
PORTABLE WATER COOLED AIR CONDITIONER.
PRODUCT MANUAL.

TABLE OF CONTENTS

- **Warnings and important information-----P3-4**
- **Technical specification-----P4**
- **System description-----P5**
- **Installation-----P5.6&7**
- **Operation-----P7-9**
- **Adding Propylene Glycol-----P10**
- **Maintenance-----P11-12**
- **Spare parts-----P13-15**
- **Wiring diagrams-----P16**
- **Pump curves and data-----P17**

WARNINGS



These instructions should be read by:

The specifying engineer.
The installation engineer.
The user.
The service engineer.



- Failure to follow these instructions may result in risk of personal injury or damage to the equipment.
- Damage due to a failure to follow these instructions will invalidate the warranty.
- The appliance must be serviced by qualified engineers in compliance with local regulations.
- The appliance must be switched off and disconnected from the power supply before any work is carried out.
- There are no user controls inside the appliance casing.
- Do not place anything on top of the appliance.
- An air gap of at least 300mm should be allowed at the front of the unit to ensure a clear airflow.
- Do not disconnect the appliance from the supply under load.
- For internal use only. Do not use out of doors.
- Extension cables should be correctly rated for the load, fully unwound and never run through water or over sharp edges.
- Always transport and store in an upright position.
- The fan motor on the external heat exchanger is electronically controlled and is liable to start and stop without notice.
- Maximum operating temperature 35°C.
- Minimum operating temperature 15°C.
- This is a class 1 appliance and must be Earthed.
- The system is supplied with a 'water only' test charge. To protect the system from corrosion and frost damage Propylene Glycol must be added prior to use. (See P10) Damage due to the failure to add Propylene Glycol will invalidate the warranty.
- Serious risk of injury! Do not support the exterior heat exchanger by means of the flexible lines.
- The air-conditioning process produces condensate (water) during operation. This condensate is pumped away from the main unit along a flexible clear line within the connecting hose assembly and is deposited to the outside from the bottom of the exterior heat exchanger. Care should be taken when positioning the exterior heat exchanger with regard to this.



This appliance contains an A2L refrigerant classified as mildly flammable. Always read the user and service manual before operation. The minimal charge within the appliance does not require a minimum room size for safe operation.

WARNING.

Do not use means to accelerate the defrosting process or to clean, other than those recommended by the manufacturer.

The appliance shall be stored in a room without continuously operating ignition sources (for example: open flames, an operating gas appliance or an operating electric heater).

Do not pierce or burn.

Be aware that refrigerants may not contain an odour.

TECHNICAL SPECIFICATIONS. MCS_e7.3-21	
Cooling capacity.	7.4 kw
Power supply.	230v. 1P. 50Hz. 13A UK plug.
Running current at 35 degrees /40% humidity.	12.5A
Refrigerant.	R454C. 750g
Weight main cooling unit (wet).	90 kg
Weight external heat exchanger unit (wet).	22 kg
Maximum permissible refrigerant pressure.	370 psi
Maximum water temperature.	50 °C
Main cooling unit noise level.	65 dB(A)
External heat exchanger unit noise level.	64 dB(A)
Main unit airflow. Maximum.	1100 m ³ /h
External heat exchanger airflow.	3100 m ³ /h
Minimum operating temperature.	15 °C
Maximum operating temperature.	35 °C
Maximum connection hose length.	35m
Maximum height of outdoor unit above indoor unit.	5m
IP rating. Indoor unit.	IP2X
IP rating. Outdoor unit.	IP24
Dimensions H/W/D	1308/805/382mm
GWP	<150

System description:

The MCS_e7.3 is a watercooled split portable air conditioning unit. It is connected to a 13 Amp. 230Vac. 50Hz power supply and comes fitted with a fused UK moulded plug.

It is recommended that the supply to the machine should be protected by a 30mA RCD

The system comprises a main indoor cooling unit, an external heat exchanger and a connecting hose assembly.

The indoor cooling unit is fitted with an automatic condensate pump as standard.

The watercooled split system uses water as a medium to remove heat generated during the cooling process to the external heat exchanger and then to the air. It is therefore important that the external heat exchanger is not sited in the same area as the main indoor cooling unit.

The system has a minimum operating temperature of 15 °C and a maximum operating temperature of 35 °C and comes fitted with a digital thermostat.

The watercooled split can run up to a maximum of 35m of connection hose. The external heat exchanger should never be sited more than 5m vertically above the main unit.

Protection for the refrigeration system is provided by automatic high and low pressure safety switches within the machine. The operation of these switches is indicated by lamps on the fascia panel. (See page 9)

The appliance is fitted with an automatic defrost which will periodically stop the fan on the external heat exchanger. This is indicated by the defrost lamp on the fascia panel.

During the normal cooling cycle the cooling lamp on the fascia panel will be illuminated.

Installation:

Site the main cooling unit and external heat exchanger in the desired locations. Ensure the locking castors are engaged on the main unit before operation.

1: Connect the main cooling unit to the external heat exchanger and connect to the power supply:

The main cooling unit, external heat exchanger and connecting hose assembly are fitted with auto-sealing water connectors to minimise water loss during connection and disconnection. It should be noted that a small amount of water loss will occur.

The female water connectors have a sliding ring which must be pulled back to make the connection. This will snap back into place once the connection has been made. (see page 7)

The water connectors are situated at the rear of the main cooling unit.

- Fit the water connectors to the main unit.
- Fit the electrical connector to the main unit.
- Fit the clear condensate hose into the push-fit connector on the main unit. (see page 6)
-

IT SHOULD BE NOTED THAT THE ELECTRICAL CONNECTORS ARE GENDER SPECIFIC AND WILL ONLY CONNECT TO THE APPROPRIATE FITTINGS. PLEASE CHECK THE CORRECT PLUG IS AT THE CORRECT END. TO DISCONNECT THE ELECTRICAL CONNECTORS DEPRESS THE GREY LOCKING PIN AND WITHDRAW THE CONNECTOR.

- Run the connecting hose assembly to the external heat exchanger in as smooth a run as possible, avoiding kinks and possible restrictions to water flow to a maximum of 35M.
- Fit the water connectors to the external heat exchanger.
- Fit the electrical connector to the external heat exchanger.
- Fit the condensate clear hose to the hose on the external heat exchanger.

MULTIPLE CONNECTION HOSE ASSEMBLIES CAN BE RUN IN SERIES SHOULD THIS BE REQUIRED TO A MAXIMUM OF 35M. TO AVOID LEAKS CHECK THAT ALL CONNECTIONS ARE FULLY HOME.

- Connect the mains lead to the power supply and check that the power supply lamp is illuminated.

Water and electrical connections:

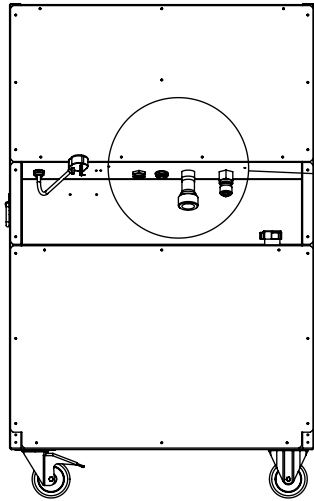

Main cooling unit

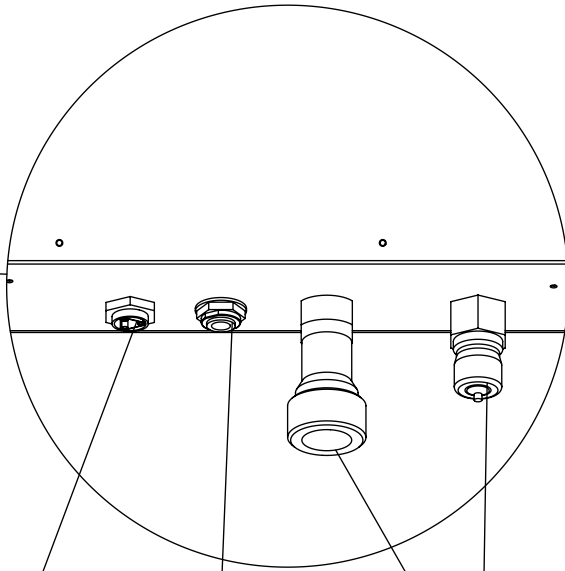

Electrical connector.

Condensate hose connector.

Water connectors.

Electrical connector.

Condensate hose connector.

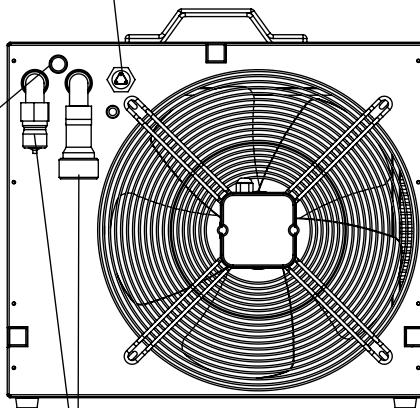

External heat exchanger

Water connectors.

Electrical connector.

Condensate hose. to fit to main cooling unit.

Water connectors.

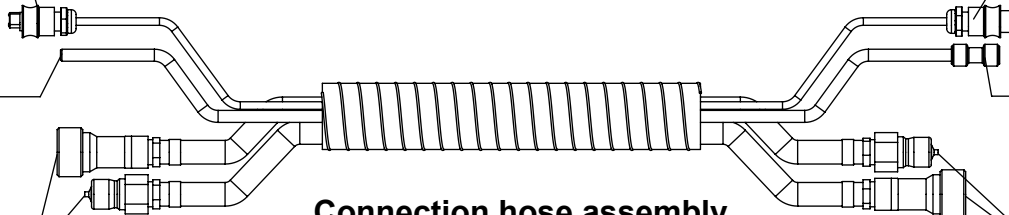

Connection hose assembly.

Electrical connector.

Push-fit condensate hose connector. External heat exchanger connection.

Water connectors.

Auto-sealing water connectors:

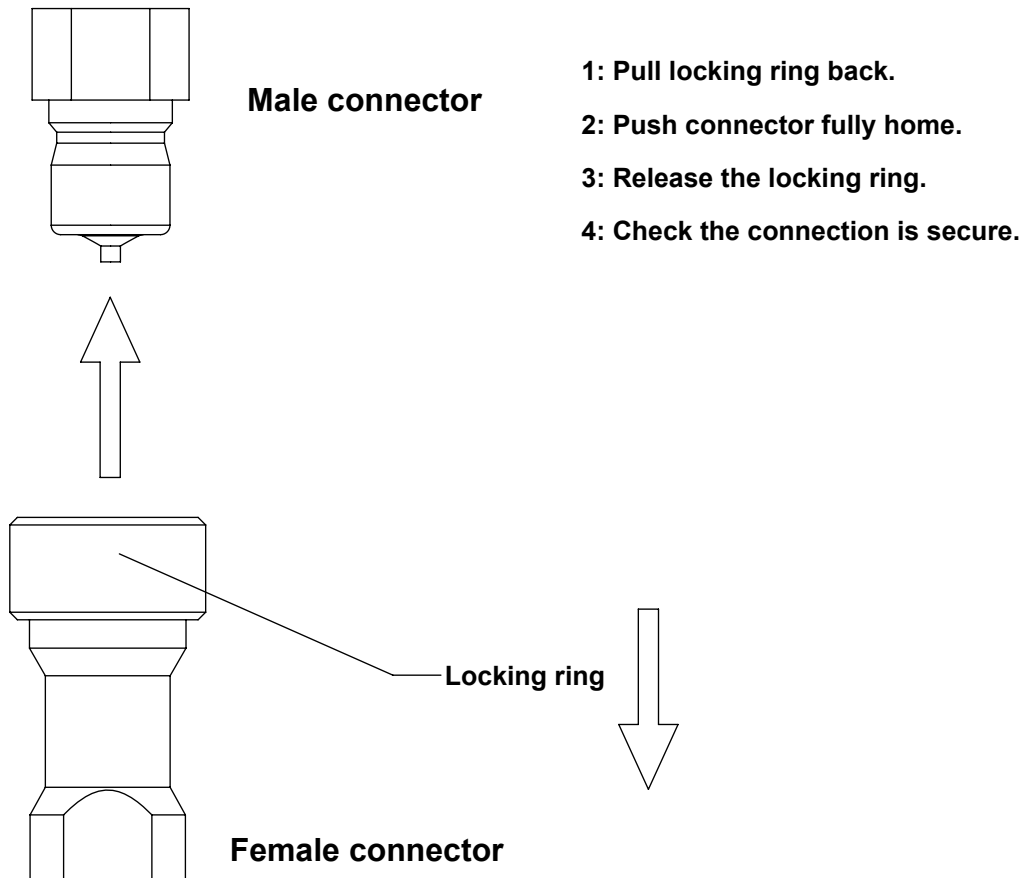

Operation:

- Turn the fan switch from 0 to 1 to start the fans on the main cooling unit. Set the fans to the desired speed using the variable fan speed control knob.
- Turn the Cooling switch from 0 to 'I' to start the compressor and water pump. It should be noted that the compressor and pump will not start if the fans are not running. The compressor will not start if the ambient temperature is below 15°C. The compressor is fitted with a start delay timer and will not run for 3 minutes from activation of the cooling switch. This device is designed to protect the compressor from repeated start/stop cycles. The compressor delay is activated each time power to the compressor is switched off, be that at the wall socket, the rocker switches or the thermostat.
- Set the digital thermostat to the desired temperature (This is the 'set point'). During normal running the digital thermostat read-out shows the ambient temperature of the room. (See P8 for setting the digital thermostat)
- The MCSe7.3 is fitted with adjustable cold air louvres. Adjust these to your preferred angle.
- It should be noted that the appliance will start in defrost mode.

Setting the digital thermostat:

How to see the set point:

- The set point is the minimum temperature the air-conditioner will operate down to.
- To see the set point push and immediately release the SET key: the display will show the set point value.
- Push and immediately release the SET key or wait for 5 seconds to display the ambient room temperature.



How to change the set point:

- The appliance comes factory set at 15°C.
- Push the SET key for more than 2 seconds to change the set point value.
- The value of the set point will be displayed and the "°C" LED starts blinking.
- To change the set point value push the up or down arrows within 10 seconds. The minimum set point is 15°C.
- To memorise the new set point value push SET key or wait for 10 seconds.

Control panel:

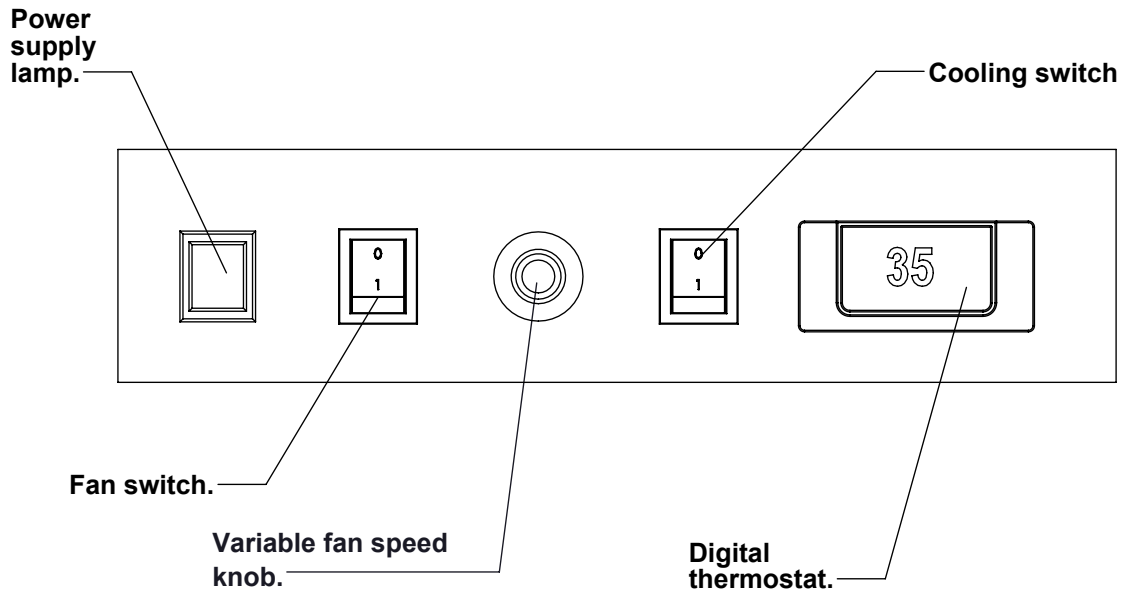

Lamp fascia panel:

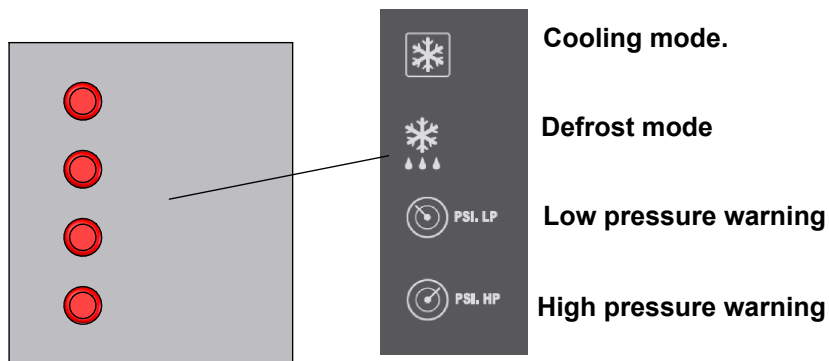

Cooling mode: This lamp will be illuminated during normal cooling when the compressor is running.

Defrost mode: This lamp will be illuminated during a defrost cycle when the external heat exchanger fan will be switched off. The appliance will start in defrost mode before cooling commences.

Low pressure warning: This lamp will be illuminated if there is a loss of refrigerant gas. The machine should not be operated if this lamp activates. This will automatically shut down the compressor.

High pressure warning: This lamp will be illuminated when the refrigeration system pressure is too high. (see fault finding). This will automatically shut down the compressor.

Adding Propylene Glycol prior to first use:

Ensure the machine is disconnected from the power supply before following this procedure.

Ensure that all local regulations are adhered to when using Propylene Glycol.

The water cooled split has a fluid capacity of approximately 10 litres when fitted with a single 5M connection hose assembly. Each extra 5M hose assembly contains approximately 2.8 litres of water.

It is recommended that a 25% Glycol to 75% water mix is used. This can be increased to 50% when the external heat exchanger is located in a very cold environment.

Failure to add Glycol could result in costly damage to the machine and will invalidate the warranty.

- 1: Connect the connection hose assembly to the main cooling unit only.
- 2: Depress the spring loaded nipple on the male connector at the end on the hose assembly into the base of a bucket or similar container.
- 3: Bleed approximately 2.5 litres of water into the bucket.
- 4: Remove the filler cap at the rear of the machine and add approximately 2.5 litres of Propylene Glycol to the tank.
- 5: Ensure that the tank is not over filled. Over filling can cause excess water to be expelled to the environment through the condensate pump.
- 6: The water tank is full when the fluid is approximately 100mm below the top of the filler spout.
- 7: Replace the filler cap.

The appliance is now ready for installation and operation.

Rear of main cooling unit.

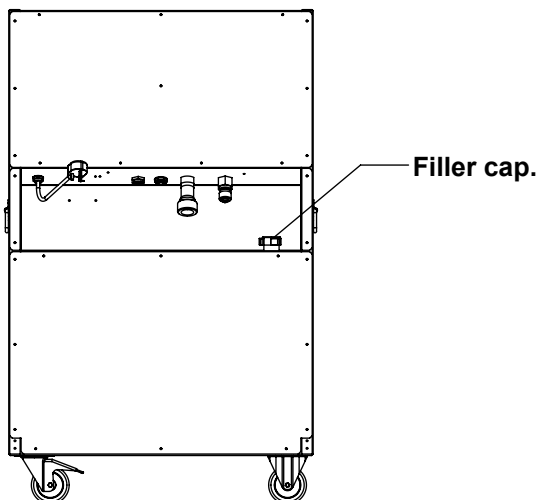

Male water connector.

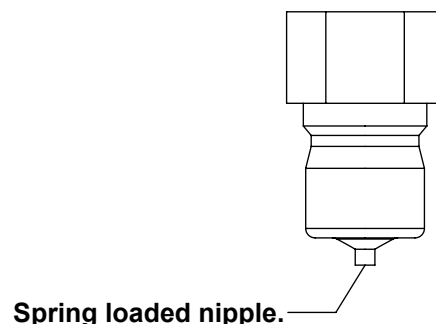



Maintenance and upkeep:

Maintenance and service work should only be carried out by competent technicians with experience and qualifications in the handling of A2L refrigerants.

The appliance should always be disconnected from the power supply before any work is carried out.

Before maintenance work is carried out all technicians should:

- a) Carry out safety checks to ensure the risk of ignition is minimised.**
- b) Operate with controlled procedures to minimise the risk of flammable gas or vapour being present while work is carried out.**
- c) Ensure all staff in the local area are instructed in the nature of the work being carried out.**
- d) Not work in confined spaces.**
- e) Check work areas with an appropriate leak detector prior to and during work to minimise the risk of flammable atmospheres.**
- f) If any hot work is being carried out an appropriate fire extinguisher should be available to hand. Either Co2 or dry powder.**
- g) All possible ignition sources should be kept sufficiently far away from the work area.**
- h) Adequate ventilation shall be provided when breaking into the refrigerant system. The ventilation should safely disperse any released refrigerant to the external atmosphere.**
- i) When replacing electrical components only spare parts specified by the manufacturer shall be used.**
- j) Electrical work should be preceded with initial safety checks:**
 - i) All capacitors need to be discharged in a manner that avoids sparks.**
 - ii) No live electrical components or wiring should be exposed while charging, recovering or purging the system.**
 - iii) There is continuity of earth bonding.**
- k) Under no circumstances should potential sources of ignition be used in the searching for or detection of refrigerant leaks.**
- l) On discovery of a leak all refrigerant should be removed before a repair is carried out. The manufacturer recommends purging the circuit with an inert gas before brazing.**
- m) Before charging ensure the refrigeration system is earthed.**

Routine checks:

- 1: Regularly check the fluid level in the water tank and top up if necessary.
- 2: Check and clean the evaporator and external heat exchanger coils. Build up of dust and dirt can severely effect the performance of the machine. Clean with compressed air.
- 3: Regularly inspect the mains cable and plug for signs of damage or wear. Do not operate the machine with a damaged mains cable.
- 4: Check that the castors are running freely and that the breaking mechanisms are working correctly.
- 5: Inspect the connection hose assembly for signs of wear or damage. Replace if necessary.

Troubleshooting guide:

PROBLEM	POSSIBLE CAUSE	SOLUTION
Machine fails to operate	Power Failure	Check power on lamp is illuminated.
		Check unit is connected to the power supply.
Check plug fuse for failure and correct 13A rating.		
Check Building circuit is not overloaded.		
	Condensate pump faulty	Check condensate pump. Replace if necessary.
Poor cooling performance.	Cooling not selected	Switch cooling on
	Thermostat set incorrectly. (Higher than ambient room temperature)	Reset the thermostat. Page9.
	Coils dirty	Clean coils. See Maintenance
	Filters dirty. (where fitted, optional extra)	Clean filters.
	Hose connection assembly over 35M	Reduce the length of the hose assembly.
	Air inlet grills obstructed	Remove obstruction.
	Water flow restricted	Check the connection hose assembly for kinks or blockages. Check all water connections are correctly fitted.
	Water pump failed	Check and replace pump.
	High or low pressure switch activated.	See below.
Water leaking.	Clogged drain hose to condensate pump.	Remove blockage and clean drip-tray.
	Water connections incorrectly fitted	Check all connections and make good.
	External heat exchanger located poorly	Move the unit to an area where draining condensate will not cause a problem.
	Damaged water hoses	Check all hoses and replace where necessary.
Compressor stops working.	Input voltage too low.	Check line voltage.
	High or low pressure switch activated.	See below.
High pressure warning lamp illuminated.	Water tank empty	Check tank and refill if necessary.
	Ambient room temperature above the maximum of 35°C.	Check temperature read-out on the digital thermostat. Do not run until room cools below 35°C.
	Water flow restricted	Check all water connections and ensure they are correct. Check hoses for signs of restrictions and re-route if necessary.
	Water pump failed	Check pump and replace.
	External heat exchanger fan faulty.	Check electrical connections on the hose connection assembly. Replace the fan if necessary.
Low pressure warning lamp illuminated.	Refrigerant loss.	Contact supplier.

MCWS250 Main cooling unit. Spare parts:

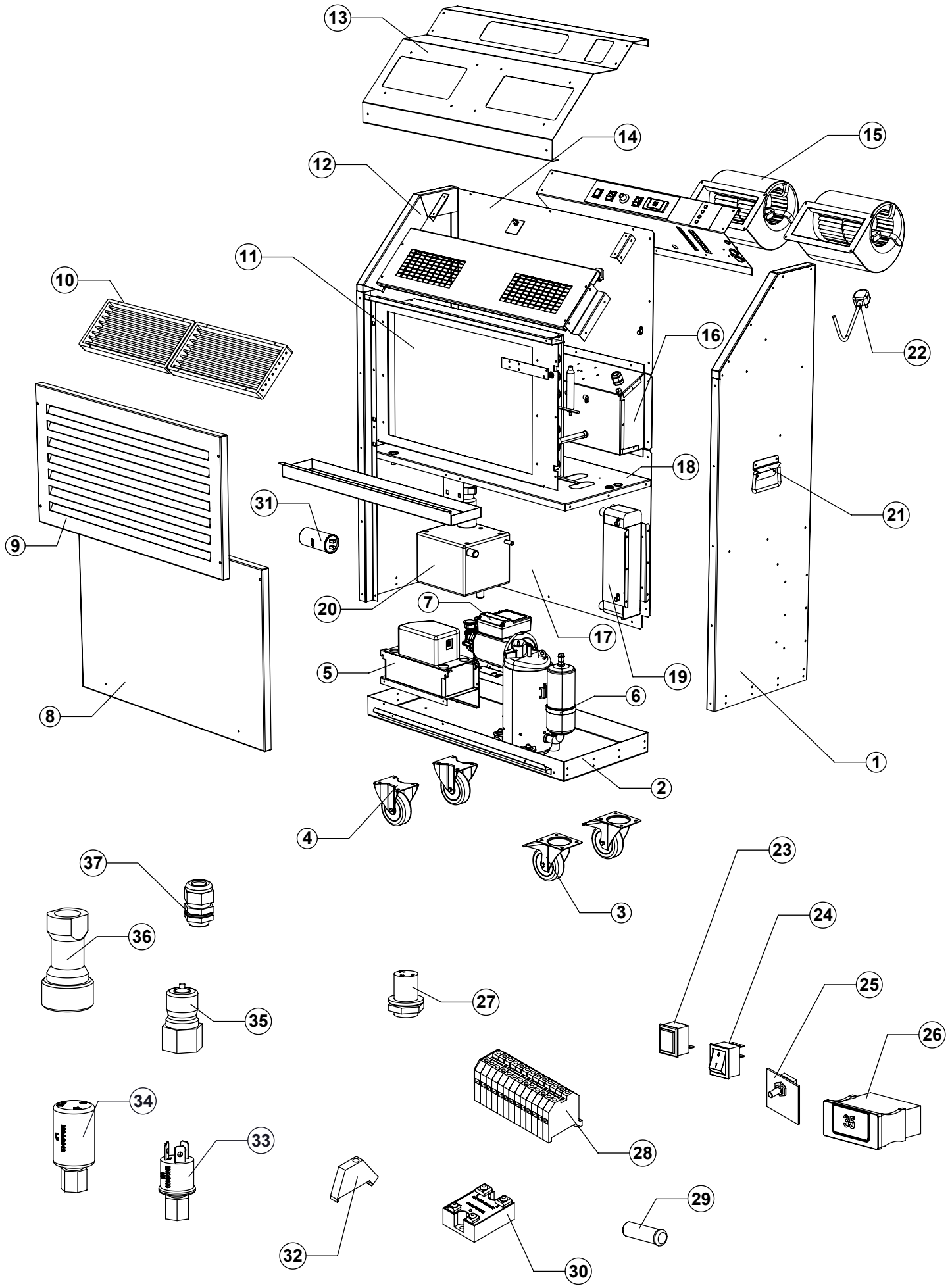

External heat exchanger. Spare parts:

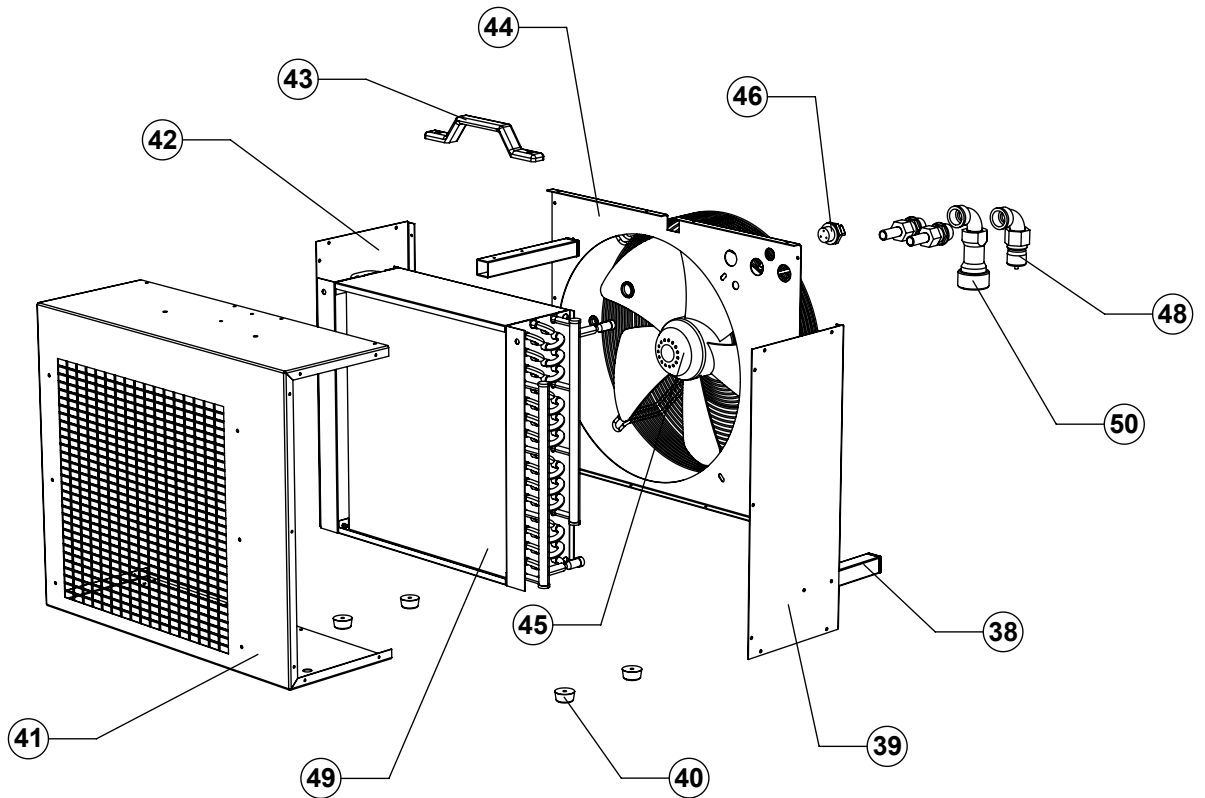

ITEM No	PART No	DESCRIPTION	PRICE
1	BW010313	RIGHT SIDE PANEL	POA
2	BW011004	BASE PANEL	POA
3	ME010212	100mm SWIVEL CASTOR	POA
4	ME010211	100mm FIXED CASTOR	POA
5	ME040105	CONDENSATE PUMP	POA
6	FR010127	COMPRESSOR	POA
7	ME0401160	WATER PUMP	POA
8	BW0201273	FRONT BOTTOM PANEL	POA
9	BW0201274	FRONT TOP PANEL	POA
10	BW010913	LOUVRE	POA
11	FR030114	EVAPORATOR COIL	POA
12	BW010410	LEFT SIDE PANEL	POA
13	BW0201276	TOP PANEL	POA
14	BW0201277	REAR TOP PANEL	POA
15	FA010317	EC FAN MOTOR	POA
16	BW010708	RECESSED PANEL ASSEMBLY	POA
17	BW0201279	REAR BOTTOM PANEL	POA
18	BW0201293	GALVANISED PANEL SET	POA
19	FR030220	PLATE HEAT EXCHANGER	POA
20	ME0401132	PLASTIC WATER TANK	POA
21	ME040316	TRUNK HANDLE	POA
22	EL020108	MAINS CABLE	POA
23	EL030704	INDICATOR LAMP	POA
24	EL030109	0/1 ROCKER SWITCH	POA
25	EL030147	FAN SPEED CONTROLLER (With Knob)	POA

Spare parts Cont'd:

ITEM No	PART No	DESCRIPTION	PRICE
26	EL030408	DIGISTAT XR30	POA
27	EL020517	PANEL MOUNT POWER SOCKET FEMALE	POA
28	EL020424	6mm TERMINAL BLOCK ASSEMBLY	POA
29	EL030709	9mm INDICATOR LAMP	POA
30	EL030215	SOLID STATE RELAY	POA
31	EL030316	45uf CAPACITOR	POA
32	EL020403	DIN RAIL END STOP	POA
33	FR010509	HIGH PRESSURE SWITCH	
34	FR010510	LOW PRESSURE SWITCH	POA
35	ME0401143	MALE COUPLER	POA
36	ME0401142	FEMALE COUPLER	POA
37	ME040201	CABLE GLAND AND LOCKNUT	POA
38	BW0201270	EXTERNAL HEAT EXCHANGER SUPPORT LEG	POA
39	BW0201112	EXTERNAL HEAT EXCHANGER RIGHT SIDE PANEL	POA
40	ME040315	RUBBER FOOT	POA
41	BW0201110	EXTERNAL HEAT EXCHANGER CASE	POA
42	BW0201111	EXTERNAL HEAT EXCHANGER LEFT SIDE PANEL	POA
43	ME040305	PLATIC GRAB HANDLE	POA
44	BW010709	EXTERNAL HEAT EXCHANGER REAR PANEL	POA
45	FA010126	400mm axial fan (Blower)	POA
46	EL020518	PANEL MOUNT POWER SOCKET MALE	POA
47	EL030306	6 uf capacitor (Axial fan)	POA
48	ME0401143	MALE COUPLER	POA
49	FR030214	EXTERNAL HEAT EXCHANGER COIL	
50	ME0401142	FEMALE COUPLER	POA
51	ME0401134	CONNECTION HOSE ASSEMBLY 5M (NOT SHOWN)	POA
52	BW030443	FASCIA LABEL SET (NOT SHOWN)	POA
53	FR020101	3/8 COPPER PIPE (NOT SHOWN)	POA
54	FR020301	20g FILTER DRIER (NOT SHOWN)	POA
55	FR010301	3/8 INSULATION TUBE (NOT SHOWN)	POA

**Wiring diagram. Live circuit.
MCSe7.3-21**

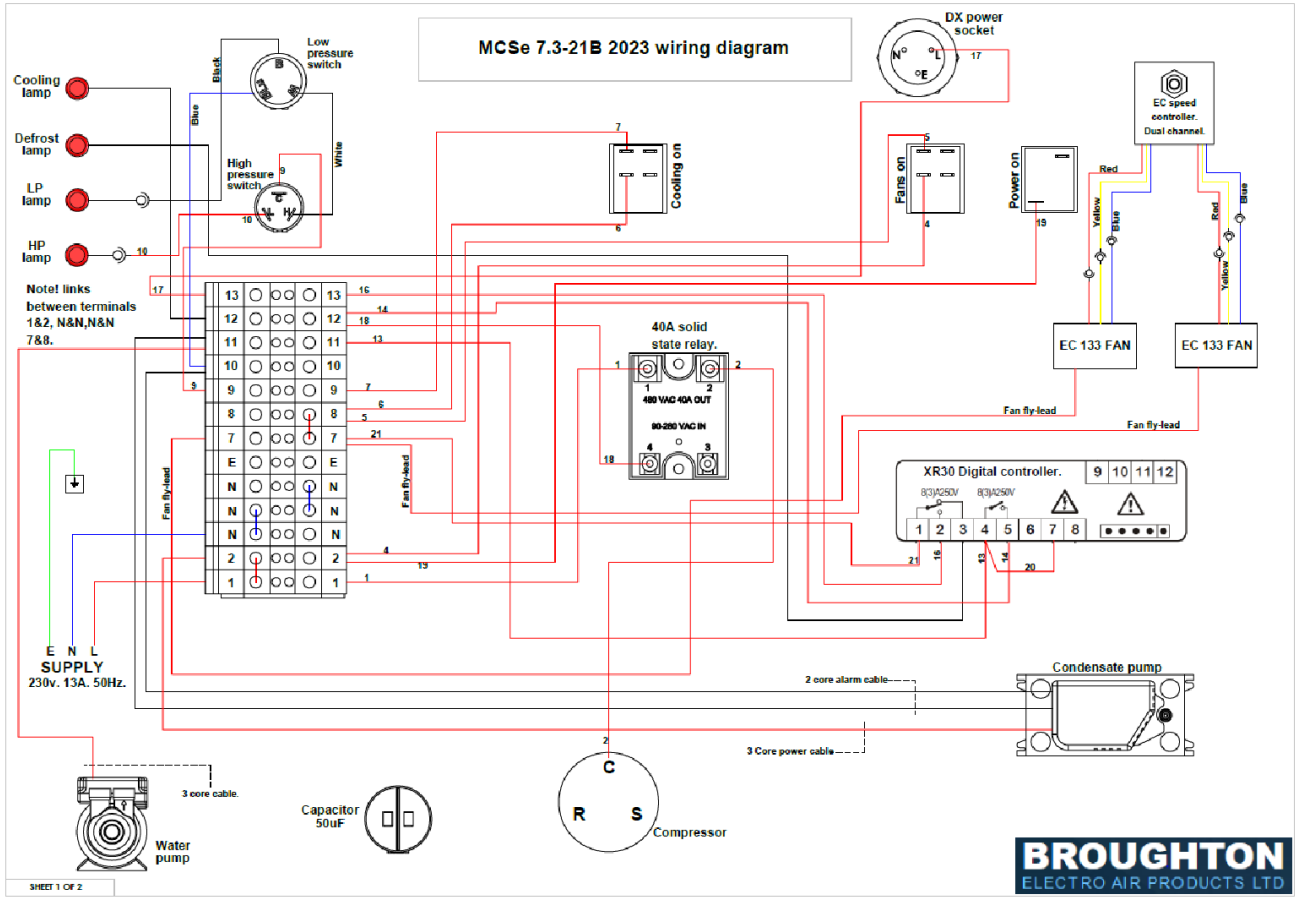

**Wiring diagram. Neutral and Earth circuit.
MCSe7.3-21**

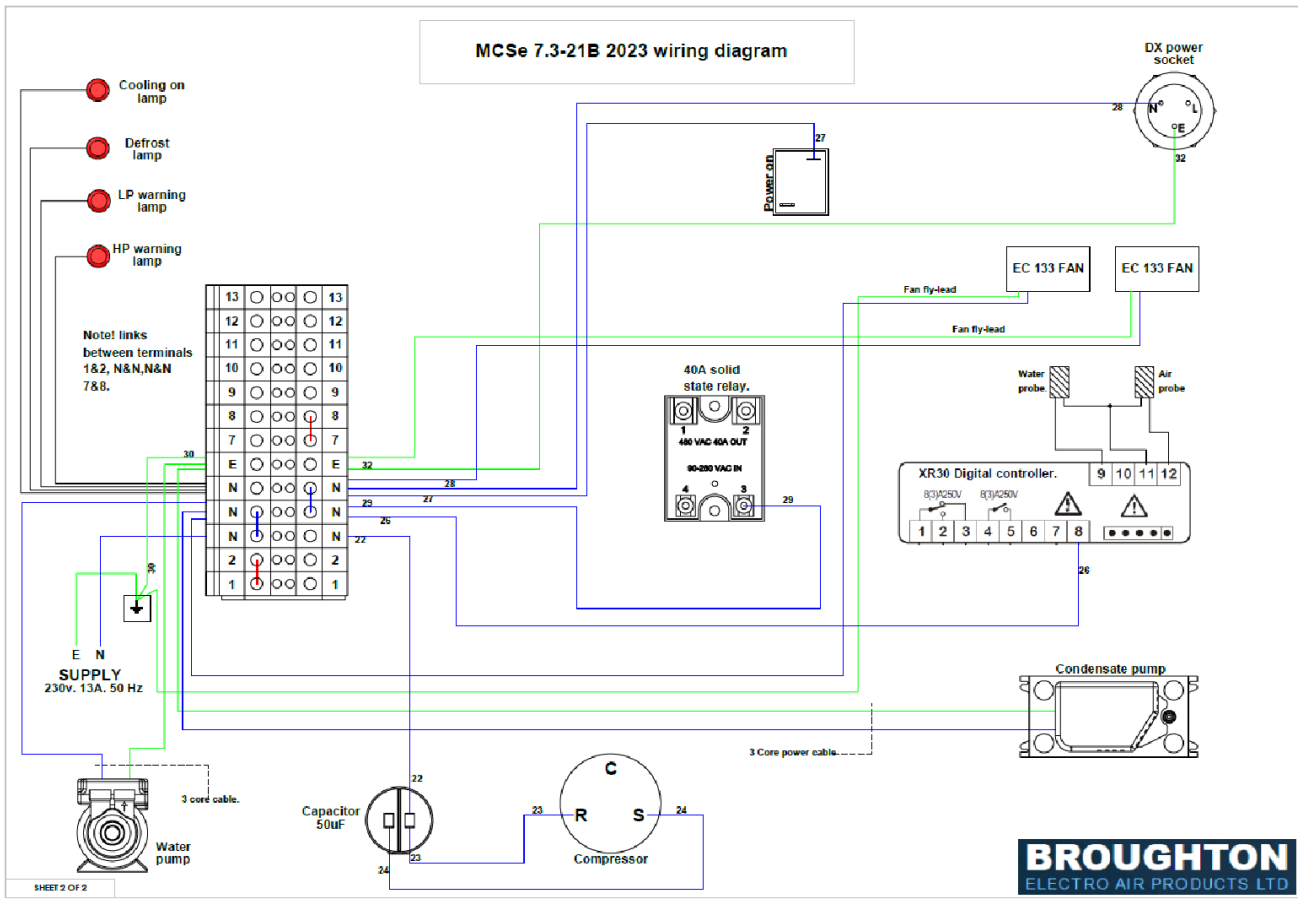

PH 45 TS water pump curve.

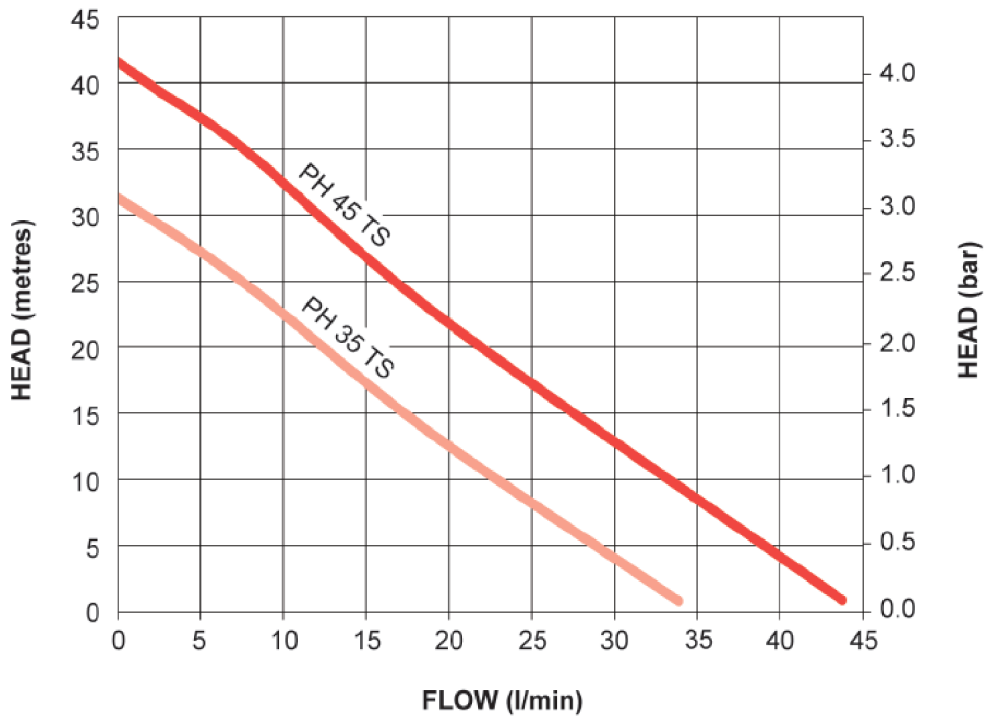

Condensate pump curve.

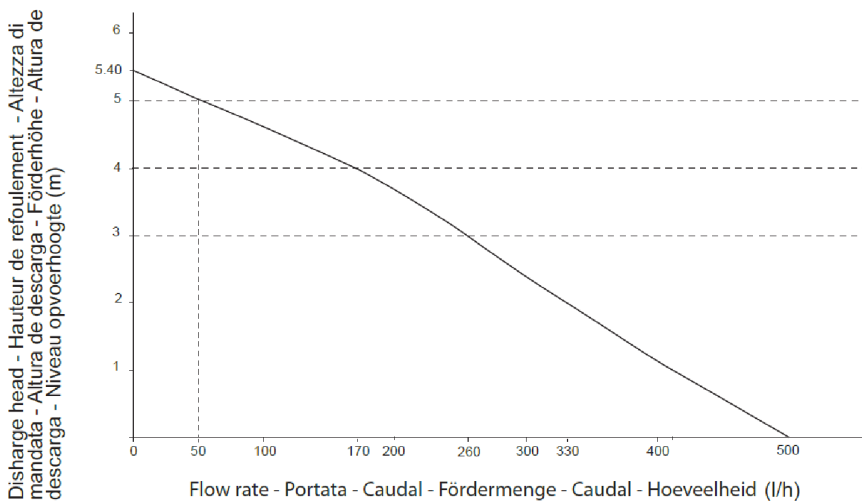

Condensate pump flow rates.(l/h).

Vertical discharge head	Total tubing length			
	5 m	10 m	20 m	30 m
1 m	380	300	240	190
2 m	310	260	200	150
3 m	240	200	145	110
4 m	150	130	80	60
5 m	30	20	0	0