

FF80

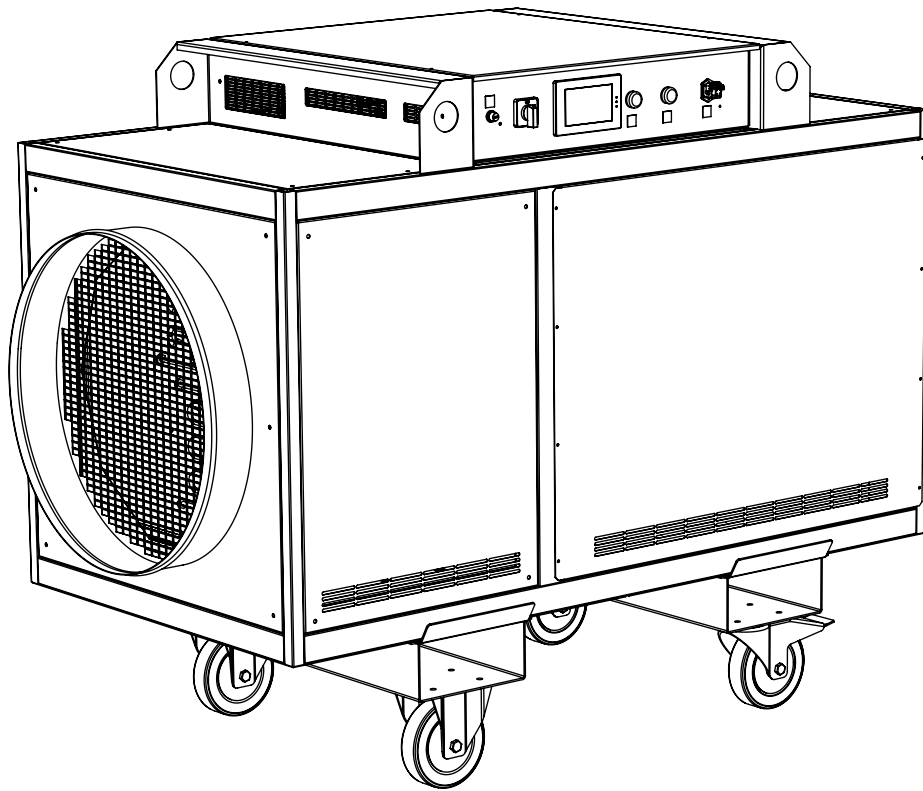

**FF80-21B
3 PHASE 400V ELECTRIC HEATER**

PRODUCT MANUAL

Contents

- **Warnings-----P3**
- **Technical specifications-----P4**
- **General product description-----P5-6**
- **Set up and operation-----P6**
- **Fan only operation-----P7**
- **Onboard thermostat operation-----P8-9**
- **Remote thermostat operation-----P10-11**
- **Automatic control operation-----P11-12**
- **Machine settings-----P13-14**
- **Using s remote thermostat-----P15**
- **Using flexible ducting-----P16**
- **Heating a room or enclosure above 40 degrees-----P16**
- **Protective/ safety devices-----P17**
- **Warning/ fault screens-----P17-19**
- **Exploded drawings-----P20-21**
- **Spare parts-----P22**
- **Maintenance/ fault finding-----P23**
- **Wiring diagrams-----P26-28**

WARNINGS

These instructions should be read by:

**The specifying engineer.
The installation engineer.
The user.
The service engineer.**









- **Failure to follow these instructions may result in risk of personal injury or damage to the equipment.**
- **Damage due to a failure to follow these instructions will invalidate the warranty.**
- **The appliance must be commissioned & serviced by qualified engineers in compliance with local regulations.**
- **The appliance must be switched off and disconnected from the power supply before any work is carried out.**
- **There are no user controls inside the appliance casing.**
- **Do not cover the appliance.**
- **Do not use in the vicinity of a pool, bath or shower.**
- **An air gap of at least 300mm should be allowed at the rear of the unit to ensure a clear airflow. Do not site the unit close to soft fabrics or combustible materials. Do not obstruct the outlet grill.**
- **Do not shut the unit down using the On/Off rotary switch. The unit must be allowed to cool after operation. (See P9)**
- **Do not disconnect the appliance from the supply under load.**
- **For internal use only. Do not use out of doors.**
- **Extension cables should be correctly rated for the load, fully unwound and never run through water or over sharp edges.**
- **Ensure that locking castors are engaged before running the unit. This is a stationary appliance and should not be moved when connected to the power supply.**
- **This unit can operate with a maximum of 100m of 600mm duct. Ducting should be kept as taut and straight as possible.**
- **The machine is fitted with an automatic phase sequence relay.**
- **This is a class 1 product and requires an Earth connection.**
- **Warning! Fan liable to start without warning.**
- **Do not use this appliance with plastic ducting.**

TECHNICAL SPECIFICATIONS. FFHT32-18	
Heating capacity.	79.5 kw
Power supply.	400v. 3P+N+E. 125A. 50Hz.
Maximum running current.	119.5A
Airflow. Max.	6000 m ³ h
Weight .	245 kg
Noise level at 3m.	76 dB(A)
IP Rating.	IP20
Maximum operating temperature.	40 °C +/- 3°C
Maximum ducting length (600mm duct) See P16.	100m
Temperature rise at 19 °C ambient. (Nominal)*	53°C
Dimensions H/W/D	1270/858/1700mm

* Outlet temperature taken at the grill at 80kW with fan at full speed.

Standards applied:

BE EN 12100. 2010.
 BS EN 60335-1. 2012.
 BS EN 60335-2. 2009.
 BS EN 61000.

MACHINE AND INSTRUCTION ICONS	
	Important information
	Warning. In order to avoid overheating, do not cover the heater.
	Safety limit thermostat.
	Over-temperature warning.
	Thermostat. (Remote)
	Power supply fault
	Risk of electric shock. Isolate from power supply before removing cover.

Please Note! The air temperature entering the machine is electronically limited to 40 degrees. Should the temperature rise above this level the heating elements will power down. The fan will continue to run.

The air temperature exiting the machine is electronically limited to 100 degrees. Should the temperature rise above this level the heating elements will power down. The fan will continue to run

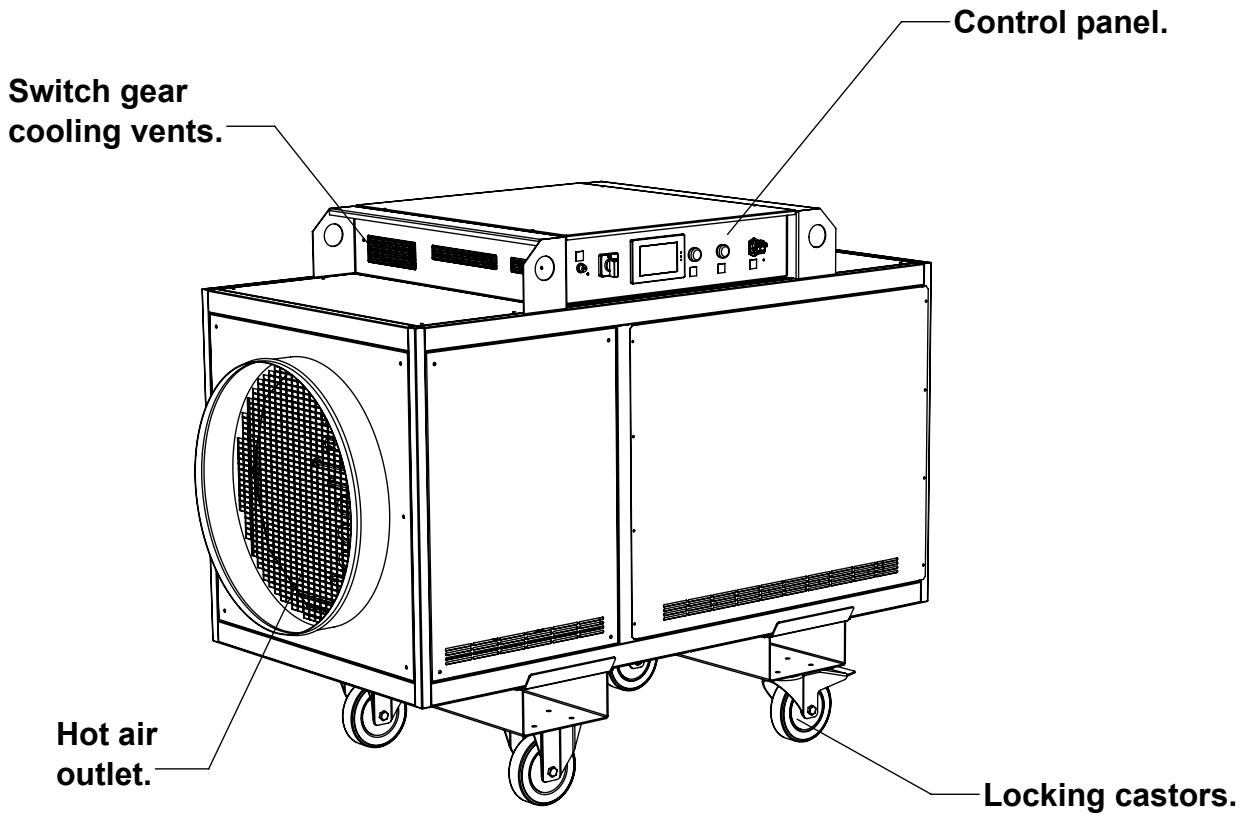

Control panel detail:

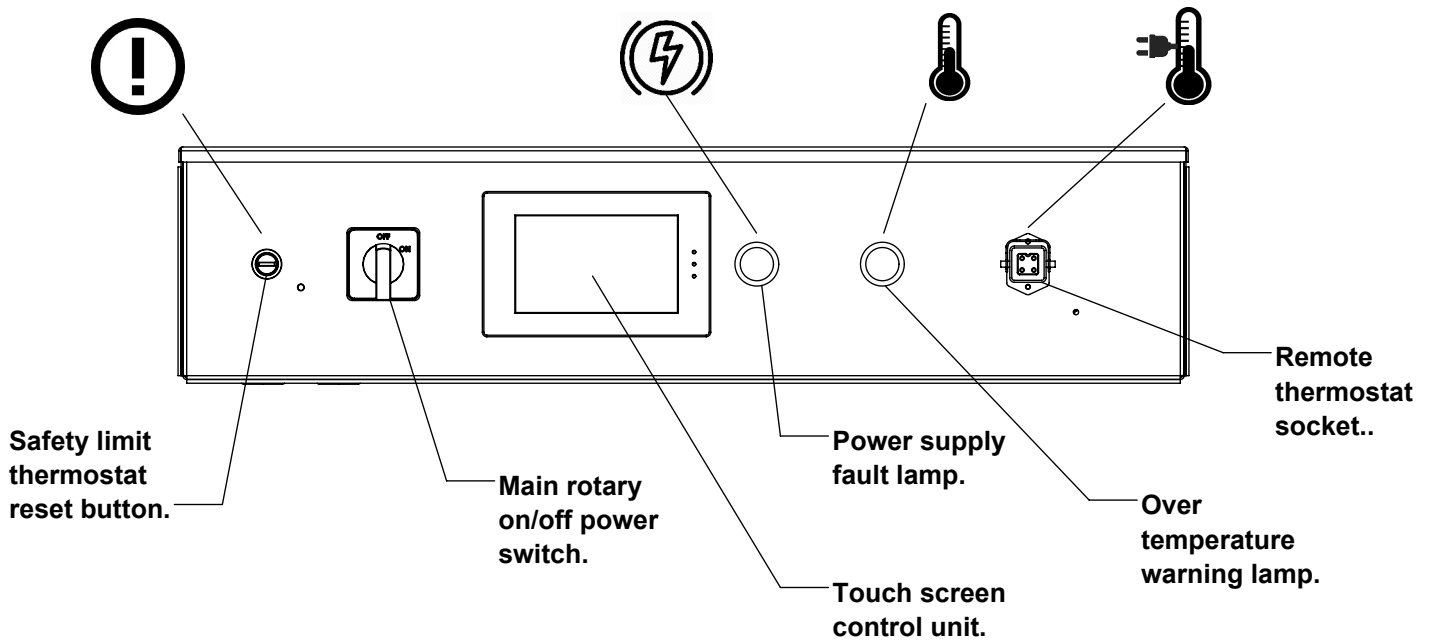

Specifications:

The FF80 is an 80kw 3 phase industrial electric fan heater.

The appliance is connected to a 400v 125Amp 3P+N+E 50Hz power supply and comes fitted with the appropriate 5 pin plug. A neutral is required. This is a class 1 appliance and requires an Earth connection.

The FF80 is fitted with a high quality backward curved fan which will allow it to operate with up to 100m of 600mm duct. (See P 16)

The FF80 is fitted with a touch screen control system as standard. An optional remote thermostat is available. (See P 15)

The FF80 is supplied with locking castors to the rear of the machine.

Setup and operation:

To start:

- Please note ! the control panel is at the side of the appliance. (See P5)
- Site the appliance on a firm level surface and apply the castor brakes. Do not operate the unit without applying the brakes. 
- Turn the main rotary power switch to I. This will power the touch screen control system.
- The controller will boot and take you to the home screen. All control options can be accessed from this screen.

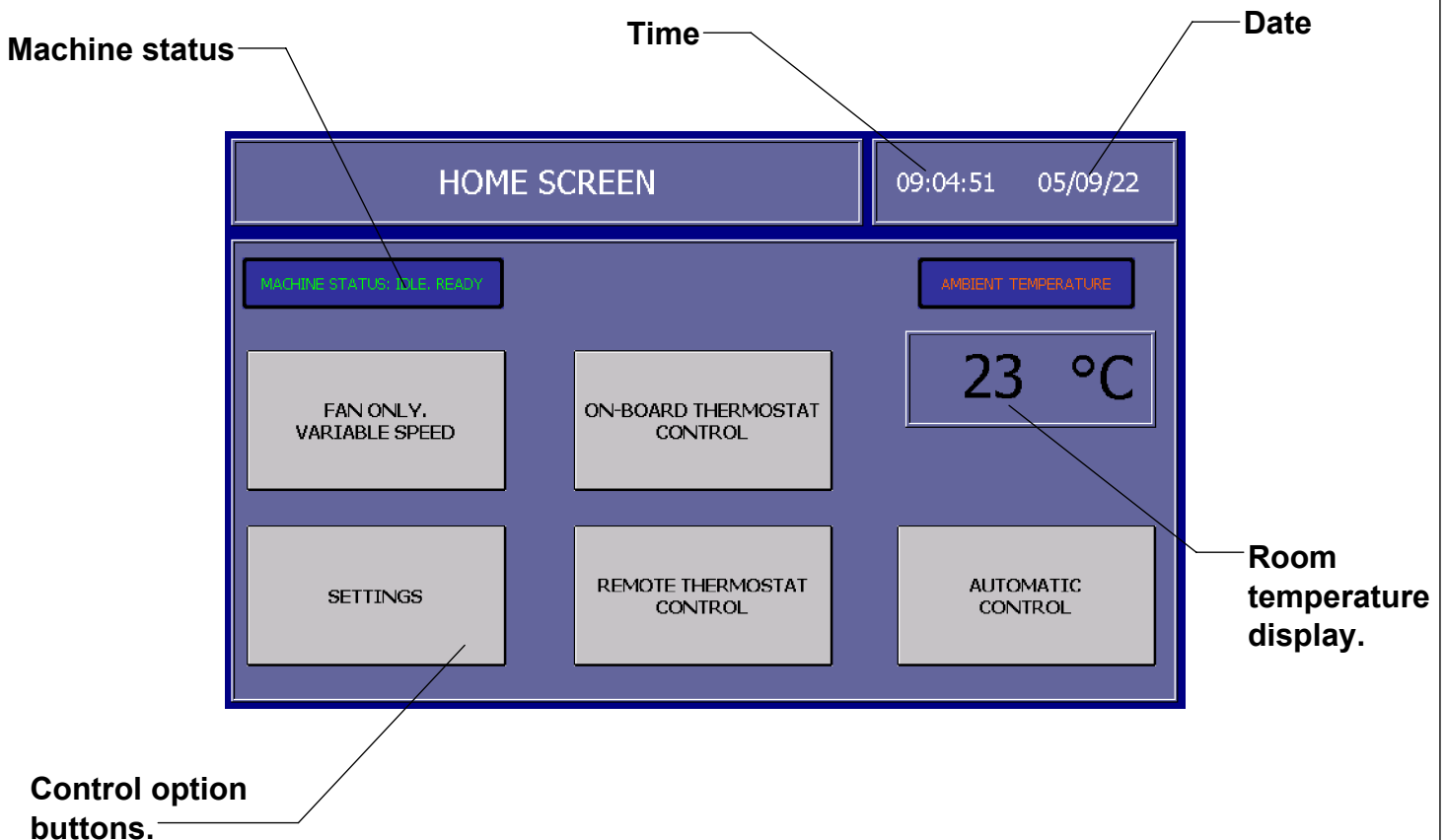

Fan only. Variable speed option:

The Fan only variable speed option will allow the user to run the fan for ventilation with no heating elements powered.

Airflow can be selected from 3000m³/h up to 6000m³/h.

The fan will start automatically at the previous speed selected. When active the fan active indicator will be animated.

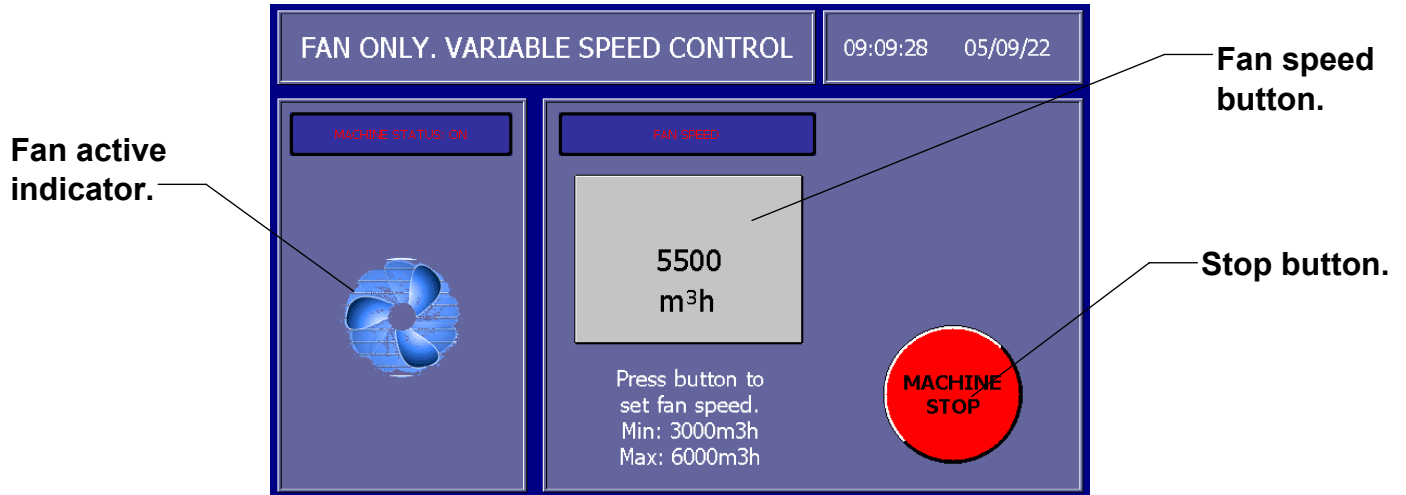

To change the fan speed press the Fan speed button. A key pad will appear.

Using the numeric keypad:

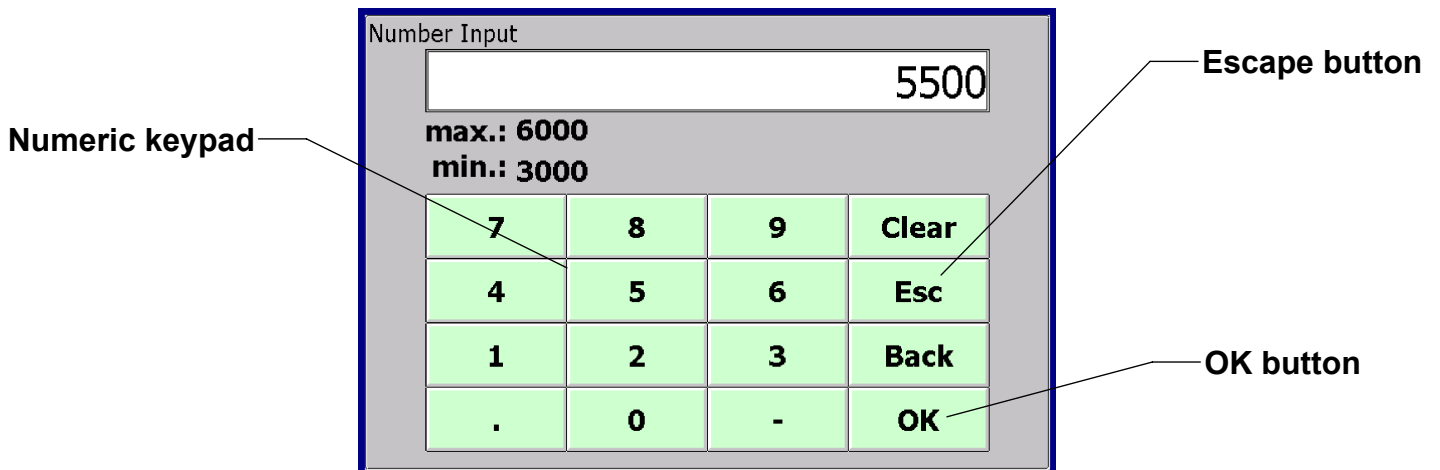

Enter the required airflow using the numeric keypad. A minimum of 3000 to a maximum of 6000m³/h.

Press the OK button to accept the setting. This will return you to the previous screen.

Pressing the Escape button at any time will return you to the previous screen.

To stop the fan press the Stop button. This will shut down the fan motor and return you to the Home screen.

Please Note! The EC fan motor will take a few seconds to start and reach speed.

Onboard thermostat option:

The Onboard thermostat option will allow the user to control the temperature of the room or area in which the heater is situated. The machine will sense the temperature entering the air inlet and heat the room to the required setting. Heating elements and the fan motor are active.

Heating elements and the fan motor are active.

The Onboard thermostat option has 2 heat settings; 48kW and 80kW. When the 48kW heat setting has been selected the user can choose between slow and fast fan speeds.

When the 80kW heat setting is selected the fan will run at full speed only.

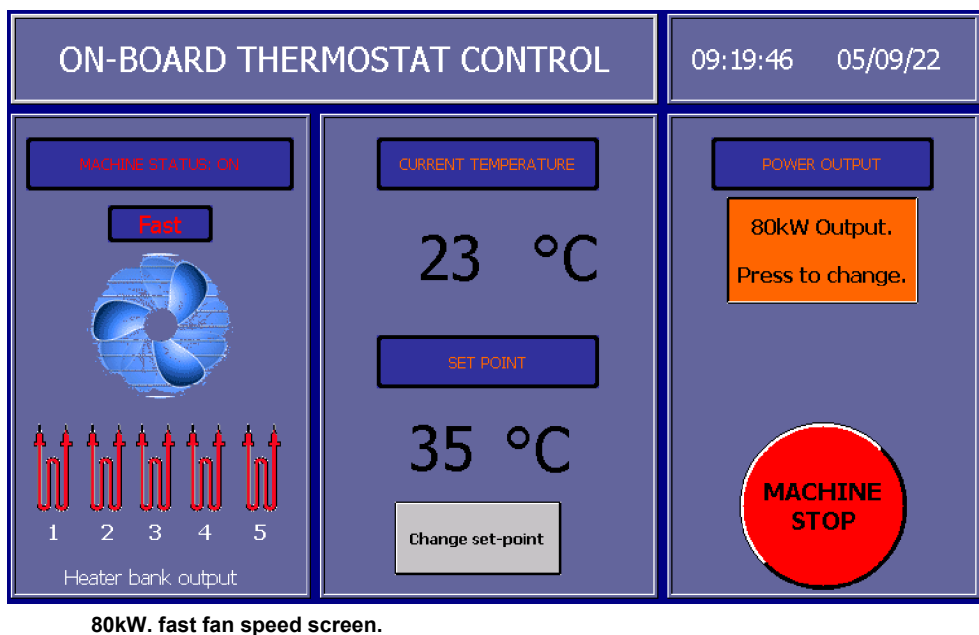
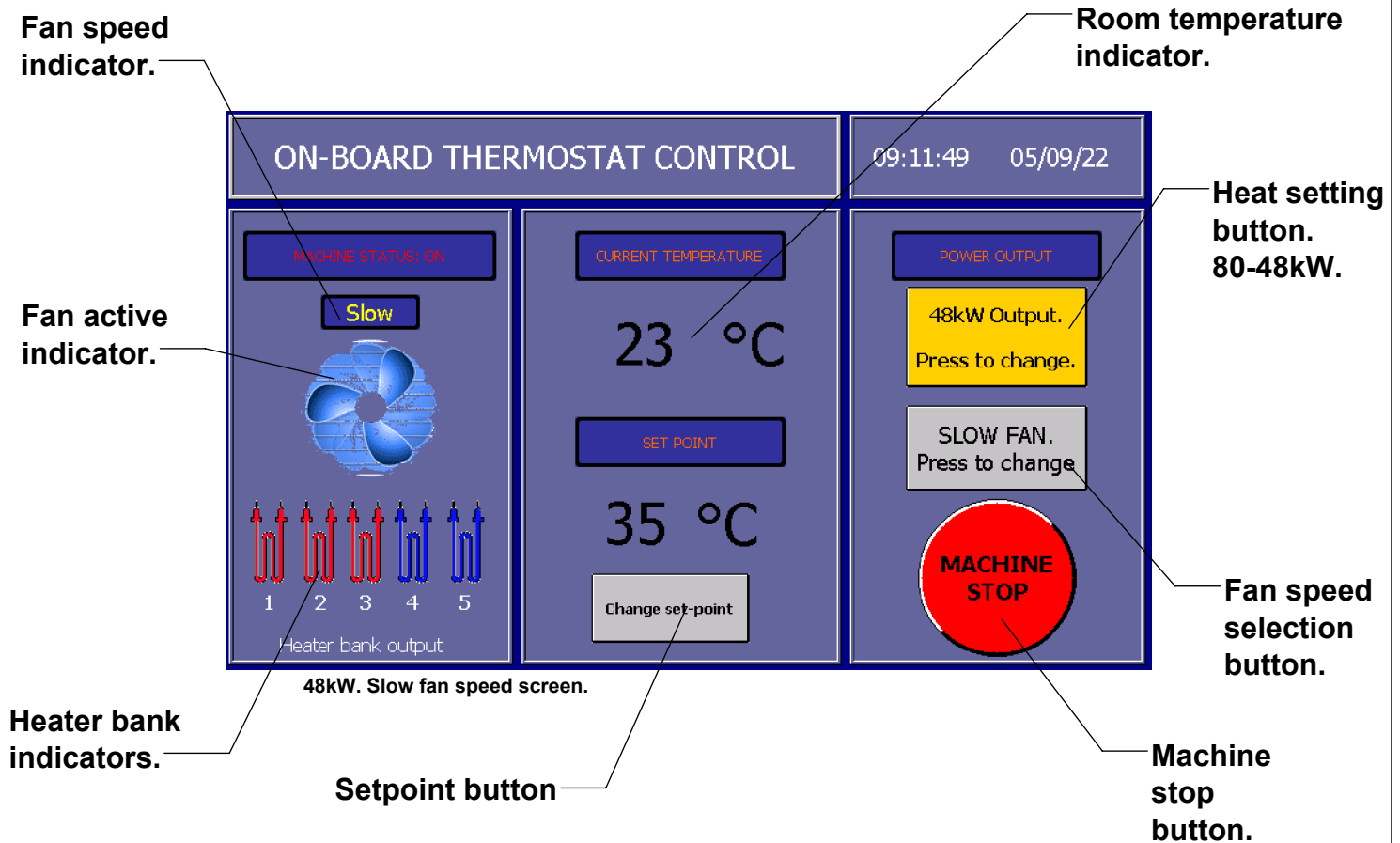

Onboard thermostat option cont'd:

To change the heat setting:

Press the heat setting button. The machine will toggle between 48kW and 80kW. If selecting 48kW a fan speed button will appear on the screen. Press to select fast or slow fan speed.

If selecting the 80kW heat setting the fan speed option will not be available and the fan will run at full speed.

To change the setpoint:

To change the setpoint press the Change Setpoint button. A numeric keypad will appear (See P7). Enter the required setpoint using the numeric keys and press Enter to accept the selection. The maximum setpoint is 40 degrees.

To shut down the machine:

Never shut down the machine using the main rotary power switch. This may cause the machine to overheat and cause nuisance tripping of the safety limit thermostat!

To shut the machine down press the Machine stop button. If the machine is operating at high temperature it will automatically go through a shutdown process. The fan will run at full speed until it is sufficiently cool. A warning screen will appear during this process. When the machine has reached a safe temperature it will automatically return to the Home screen.

The rotary power switch can then be turned to the off position.

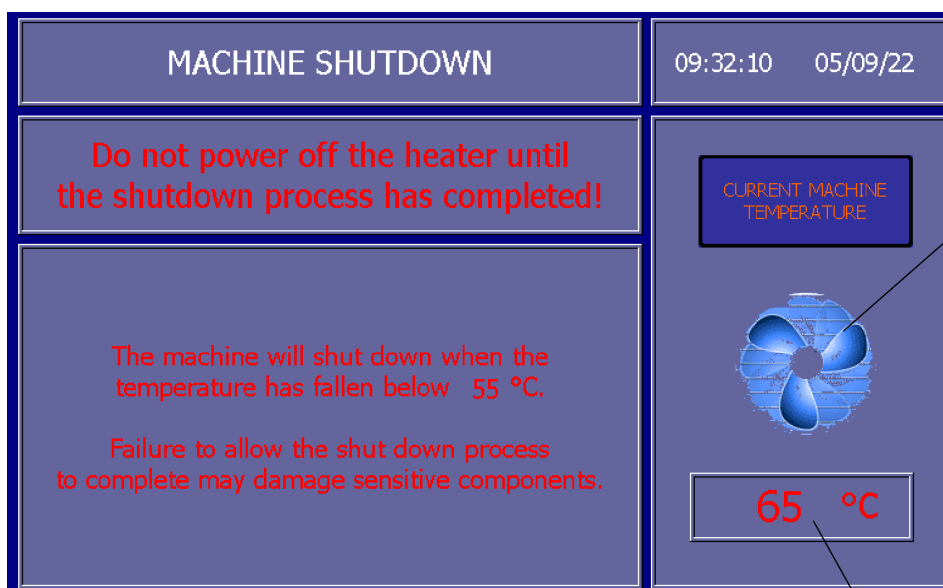

Machine shutdown warning screen.



Fan active indicator.

Current air outlet temperature.

Remote thermostat option:

The Remote thermostat option will allow the user to fit a remote thermostat to the unit. Heating elements and the fan motor are active.

The Remote thermostat option has 2 heat settings; 48kW and 80kW. When the 48kW heat setting has been selected the user can choose between slow and fast fan speeds.

When the 80kW heat setting is selected the fan will run at full speed only. The remote thermostat screen has no setpoint option as this is controlled by the remote thermostat.

Connect the remote thermostat before activating this option. (See P15)

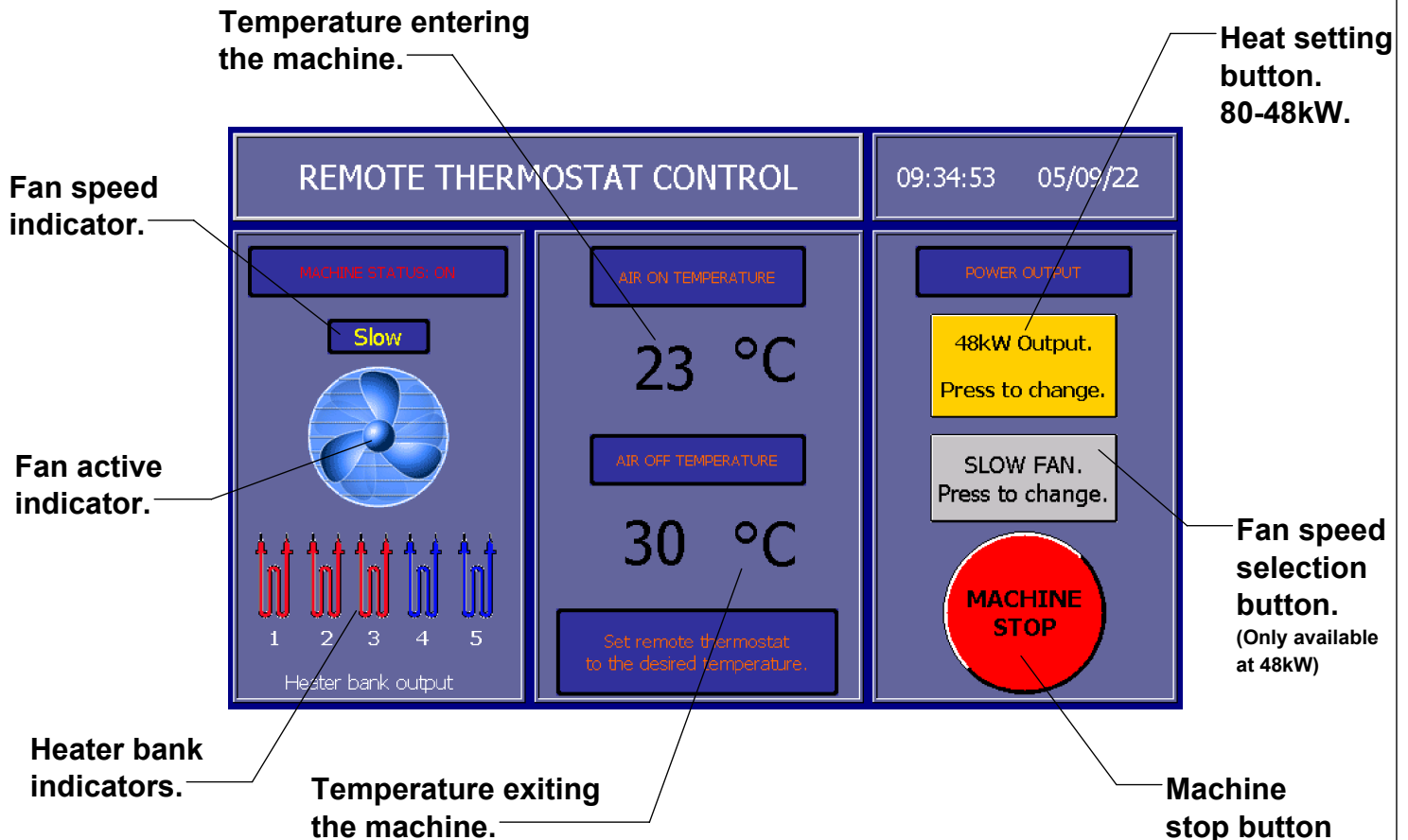

To change the heat setting:

Press the heat setting button. The machine will toggle between 48kW and 80kW.

If selecting 48kW a fan speed button will appear on the screen. Press to select fast or slow fan speed.

If selecting the 80kW heat setting the fan speed option will not be available and the fan will run at full speed.

Remote thermostat option cont'd:



To shut down the machine:

Never shut down the machine using the main rotary power switch. This may cause the machine to over heat and cause nuisance tripping of the safety limit thermostat!

To shut the machine down press the Machine stop button. If the machine is operating at high temperature it will automatically go through a shutdown process. The fan will run at full speed until it is sufficiently cool. A warning screen will appear during this process. When the machine has reached a safe temperature it will automatically return to the Home screen. (See P6)

Automatic control option:

The Automatic control option allows the user to choose between 5 pre-defined settings. These settings define the Delta T of the machine (Temperature off minus temperature on) and airflow.

These settings include:

- Delta T 15 degrees. Fan at 6000m³/h.
- Delta T 25 degrees. Fan at 6000m³/h.
- Delta T 40 degrees. Fan at 6000m³/h.
- Delta T 40 degrees. Fan at 4000m³/h.
- Delta T 60 degrees. Fan at 4000m³/h.

Once selected there are no user controls to change these settings.

It should be noted that the Delta T is calculated at the air intake grill and air outlet grill.

Pre-defined settings buttons.

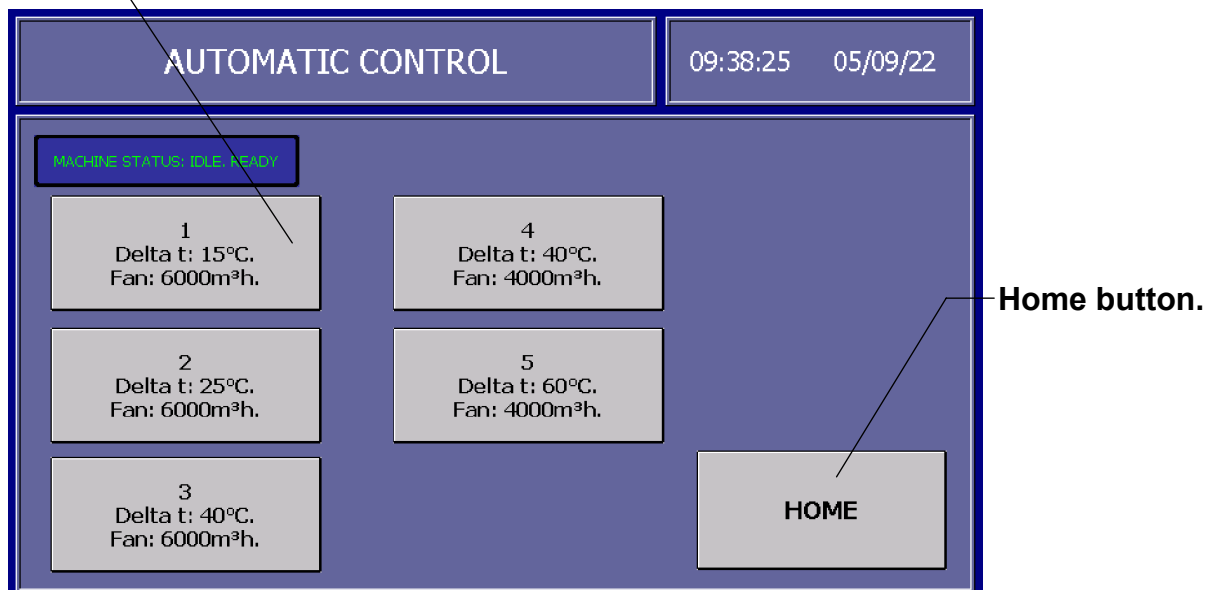

Automatic control option cont'd:

Once an option is selected the appropriate option screen will appear. The heater will begin to operate. The heating elements and fan motor will be active.

Machine settings cannot be changed by the user.

Air on
temperature
display.

Delta T
setpoint.

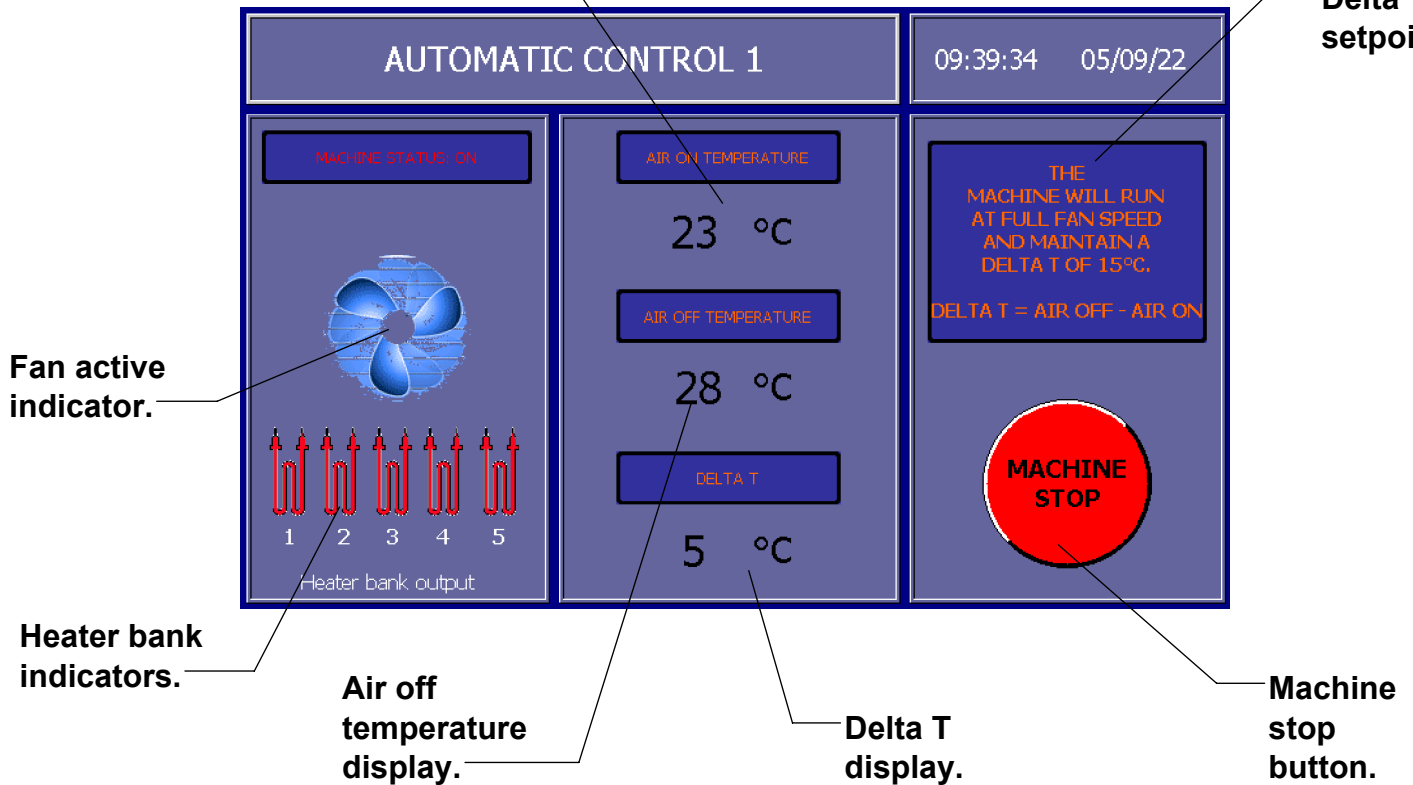

To shut down the machine:

Never shut down the machine using the main rotary power switch. This may cause the machine to over heat and cause nuisance tripping of the safety limit thermostat!

To shut the machine down press the Machine stop button. If the machine is operating at high temperature it will automatically go through a shutdown process. The fan will run at full speed until it is sufficiently cool. A warning screen will appear during this process(P9). When the machine has reached a safe temperature it will automatically return to the Home screen. (See P6)



Settings option:

The following settings can be accessed through the settings button on the Home screen. Only experienced technicians should change these settings.

- **Trim.** This controls the point at which the relay outputs de-activate before the setpoint. This has a minimum of 0 degrees and a maximum of 5 degrees. The machine comes factory set at 2 degrees.
- **Fine trim.** This controls the point at which the transistor outputs de-activate before the setpoint. This has a minimum of 0 degrees and a maximum of 5 degrees. The machine comes factory set at 0 degrees
- **Calener.** The time and date can be changed by selecting this option.
- **Service warning reset.** The service timer can be reset using this option.
- **Password edit.** The password can be changed using this option. It should be noted that a record should be kept of any new password as failure to do so would prevent access to some of the controllers features.
- **Manufacturers settings.** These can only be accessed by the manufacturer.
- **Screen settings.** The screen contrast and brightness can be changed by selecting this option.

To access the settings menu:

- Press the Settings button on the Home screen (See P6).
- You will be prompted for a 4 digit Password. (This is factory set at 1-2-3-4).
- All settings are input using the numeric keypad. (See P7).

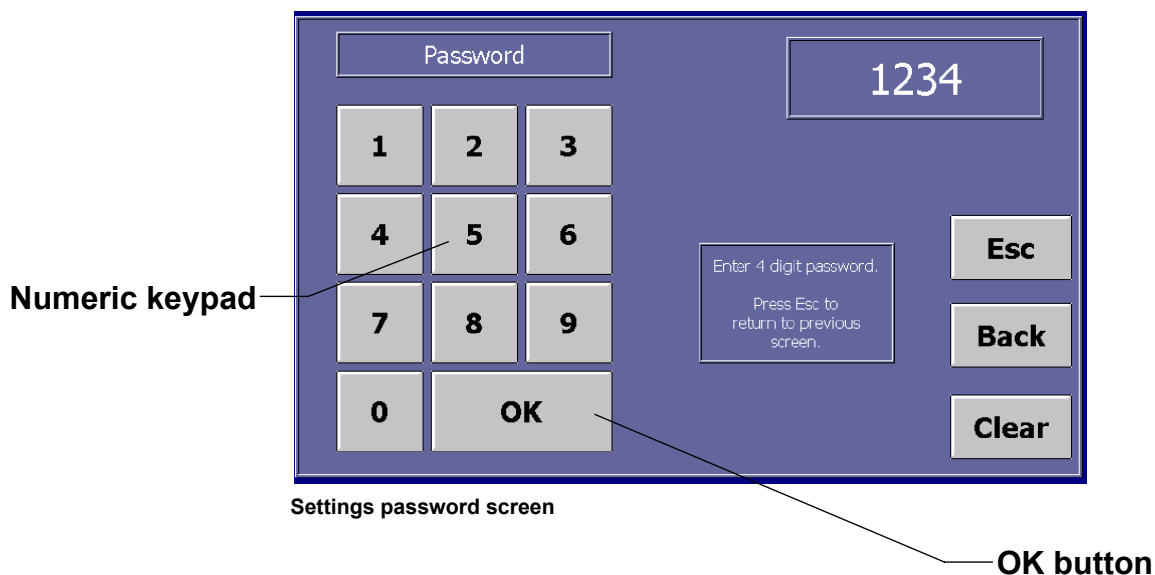

Service timer:

After 1000 hours of operation the service due warning will flash on the home screen. This will not disable the machine but acts as a warning that a service is due. It is important for the safe operation of the heater that regular service is carried out.

The service timer can be reset in the Settings options. See P13.

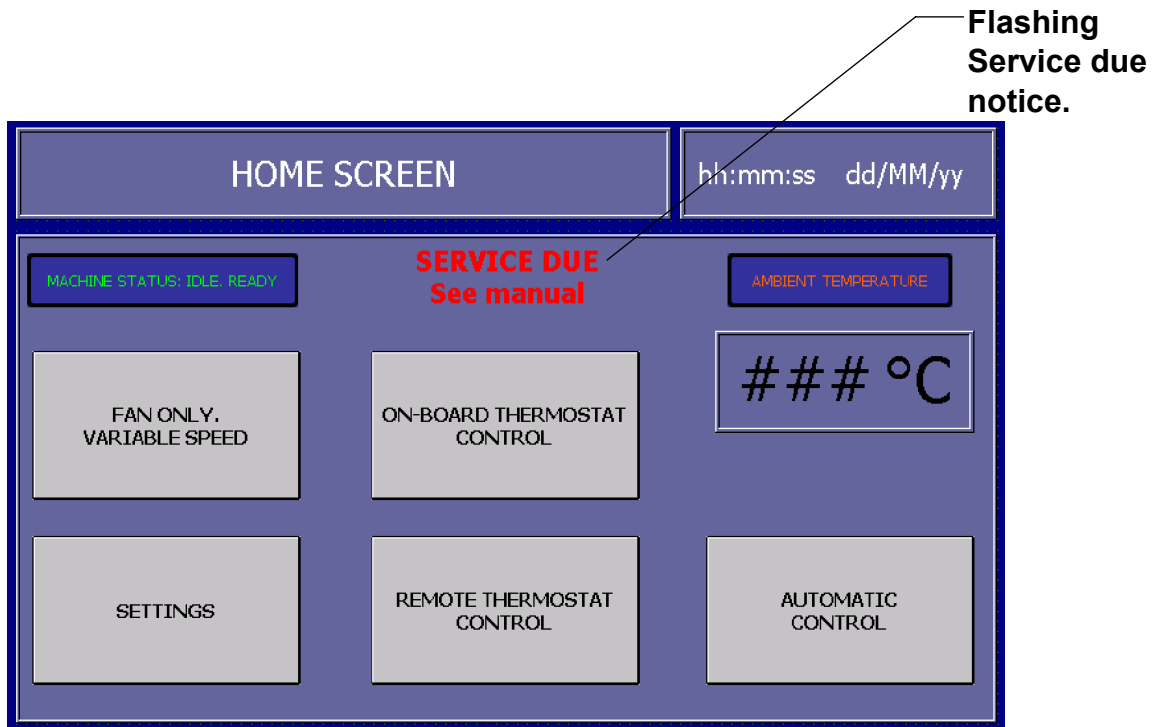

For servicing and regular maintenance see P23.

Fitting the remote thermostat:

- Lift the retaining catch and remove the protective cap from the remote thermostat socket. The thermostat socket is located on the control panel.
- Fit the remote thermostat plug to the socket and secure in place with the retaining catch.
- Set the controller to Remote thermostat control.
- The remote thermostat is now ready for use.
- Always refit the protective cap when not in use.

Remote thermostat:

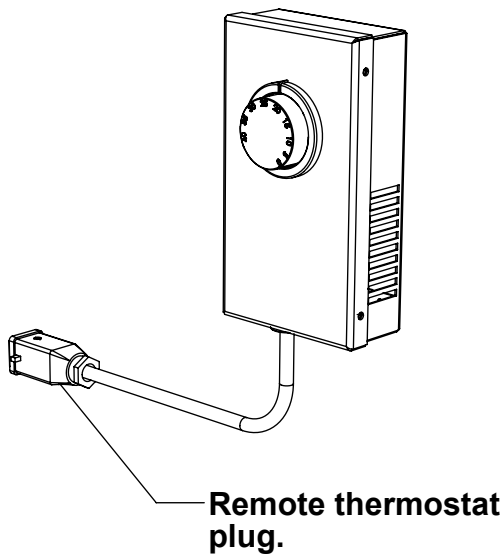

Remote thermostat socket:

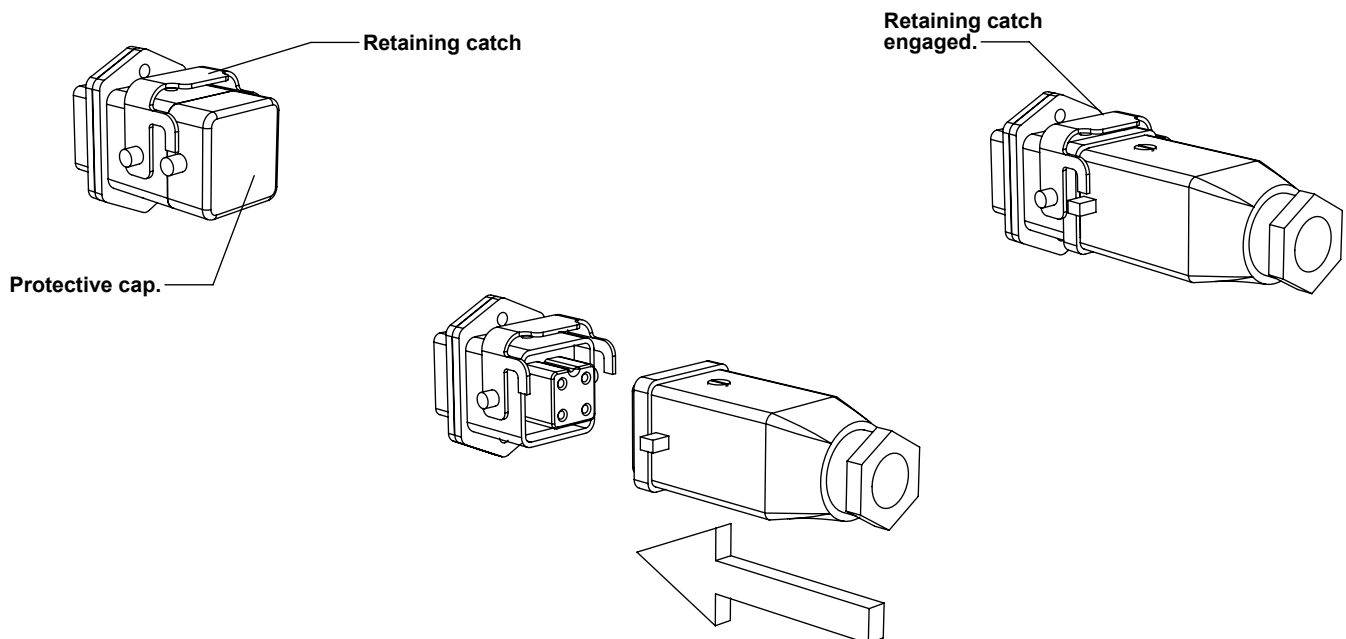

Using flexible ducting:

- This appliance is designed to be operated with a total maximum flexible duct length of 100m.
- 600mm ducting should be fitted. Do not use reducers.
- Aluminium foil duct is recommended. Do not use plastic flexible duct.
- Always keep duct lengths to a minimum.
- Always keep duct runs as straight as possible.
- Poorly run flexible ducting can cause overheating of the machine. Do not run ducting through 180 degrees.

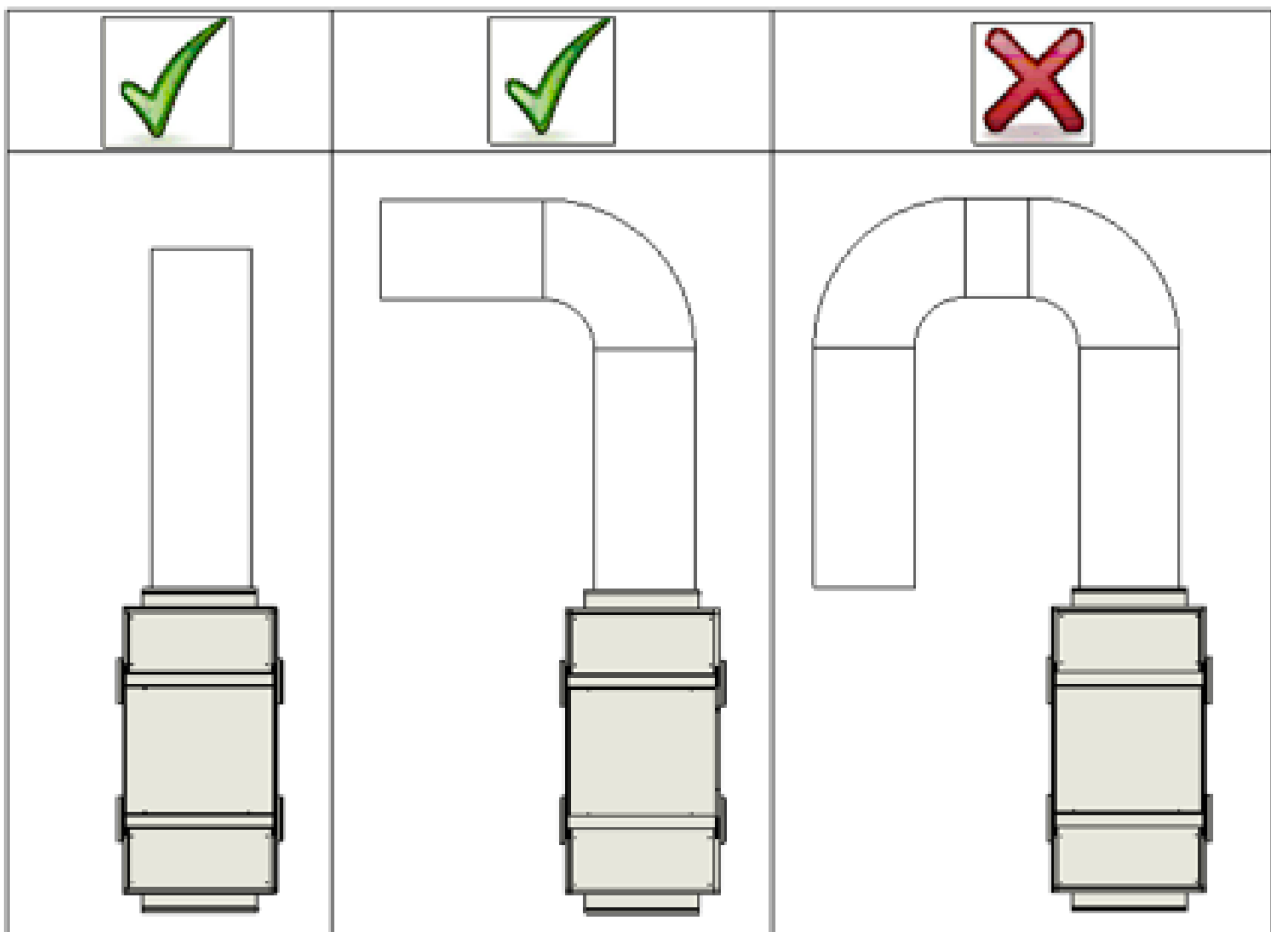

Heating a room or enclosure to temperatures above 40 °C:

The FF80 uses thermal protective devices that will shut the machine down if operated in an ambient temperature above 40 °C.

To heat a room or enclosure to temperatures exceeding 40 °C it will be necessary to site the unit outside of the area and duct the hot air in. The ducting should be kept as short as possible and insulated duct is recommended.

To control the temperature above 40 °C a remote high temperature thermostat should be used. These can be supplied as an optional extra.

Protective /safety devices:

- The FF80 is fitted with a safety limit thermostat. This is a fail-safe device. Should the maximum design operating temperature be exceeded it will shut down the heating elements. The fan will run at full speed until cool. A warning lamp will illuminate on the control panel and a fault screen will appear on the control unit. This device requires a manual reset and should only operate in the event of a fault. Any activation of this safety device should be investigated by a competent engineer. This device can nuisance trip if the correct shut-down process is not followed.
- The FF80 is fitted with limit thermostats. Should the maximum operating temperature be exceeded they will shut down the heating elements and leave the fan running. These devices will automatically reset once the temperature falls to an acceptable level. No warnings are indicated on the control unit screen.
- The machine is fitted with a fan motor overload device. In the event of a fan fault this will shut down the heating elements and the fan motor. A warning will appear on the control unit screen.
- The FF80 is fitted with a phase sequence relay. In the event of incorrect phase sequence this will automatically switch 2 phases and ensure the correct rotation of the fan motor. In the event of a phase loss it will shut down the heating elements and the fan motor. A warning lamp will illuminate on the control panel.

Warning/ fault screens:

The FF80 control unit is equipped with a number of warning/ fault screens to aid in fault diagnosis.

Fan Motor overload:

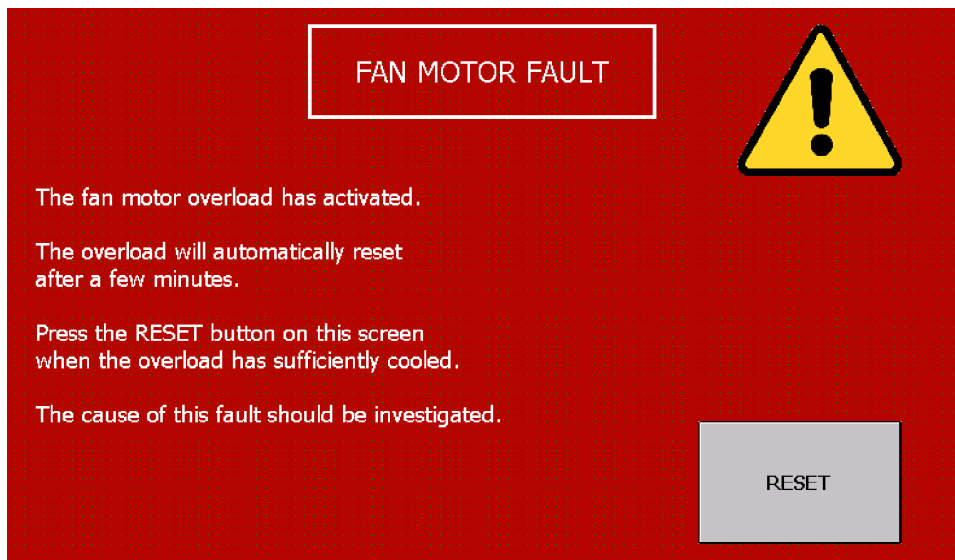

This indicates that the fan motor thermal overload has tripped due to excessive current. The heater cannot operate with this fault. Switch the machine off. The thermal overload will automatically reset once it has cooled sufficiently. Power on the machine and press the Reset button. This will return you to the Home screen. The cause of this fault should be investigated.

Warning/ fault screens cont'd:

Pt100 probe failure:



The screenshot shows a red warning screen with a white box at the top containing the text "PT100 PROBE ALARM". Below this, the text reads "AIR OUTLET PROBE FAILURE. THE HEATER CAN NOT OPERATE WITH THIS FAULT." followed by a list of four steps: "1: SWITCH OFF AND DISCONNECT MACHINE FROM POWER SUPPLY.", "2: CHECK PROBE WIRE CONNECTIONS.", "3: REPLACE PROBE.", and "4: RECONNECT TO THE POWER SUPPLY AND SWITCH ON." To the right of the text is a yellow triangular warning icon with a black exclamation mark.

One of two warning screens will appear to indicate a fault with either the inlet temperature probe or the outlet temperature probe.

The heater cannot operate with this fault. Switch the machine off and disconnect from the power supply. The probe wiring should be checked for loose connections or damaged insulation. If necessary replace the probe.

Over temperature alarm:

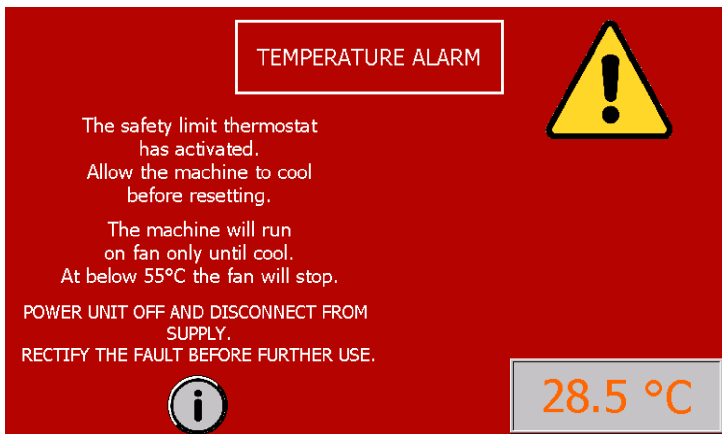

The screenshot shows a red warning screen with a white box at the top containing the text "TEMPERATURE ALARM". Below this, the text reads "The safety limit thermostat has activated. Allow the machine to cool before resetting. The machine will run on fan only until cool. At below 55°C the fan will stop." followed by the instruction "POWER UNIT OFF AND DISCONNECT FROM SUPPLY. RECTIFY THE FAULT BEFORE FURTHER USE." To the right of the text is a yellow triangular warning icon with a black exclamation mark. At the bottom left is a white information icon (i in a circle), and at the bottom right is a grey box displaying the temperature "28.5 °C".

The safety limit thermostat has activated. This indicates excessive temperatures within the heater.

The heater will run on fan only until cool. All functions will then shut down. Switch the machine off and disconnect from the power supply.

Check the following:

- 1: That duct runs are free of obstructions and are as short as possible.
- 2: Adequate clearance has been allowed at the air inlet grill.
- 3: The fan motor is operating correctly.
- 4: The machine has been correctly shut-down following previous use (nuisance tripping).

Once the fault has been located remove the black plastic cover on the safety limit thermostat(Located on the left side of the control panel) and press the reset button. Always replace the cap.

Warning/ fault screens cont'd:

Incorrect shut-down fault:

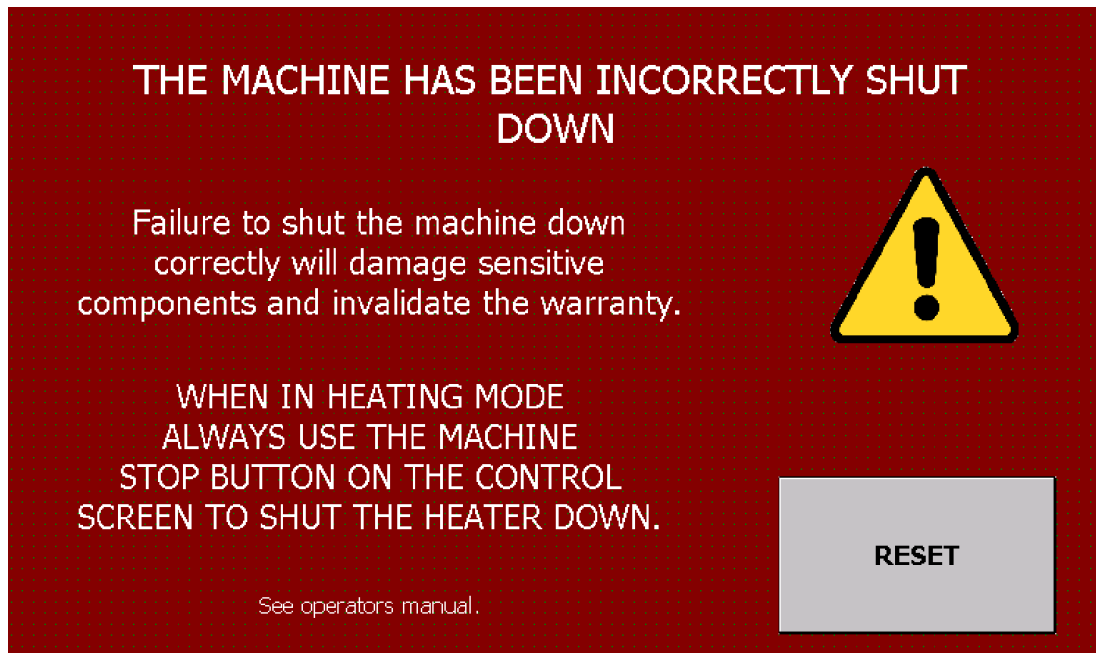

The incorrect shut-down fault has activated. This indicates that the last time the machine was used the correct shut-down process was not followed.

Never use the rotary switch to shut the machine down when in heating mode.

Always use the Machine Stop button on the control unit screen. This will allow the fan motor to cool the unit and prevent damage to sensitive components.

To exit the fault screen press the reset button. This will return you to the Home screen.

Exploded view:

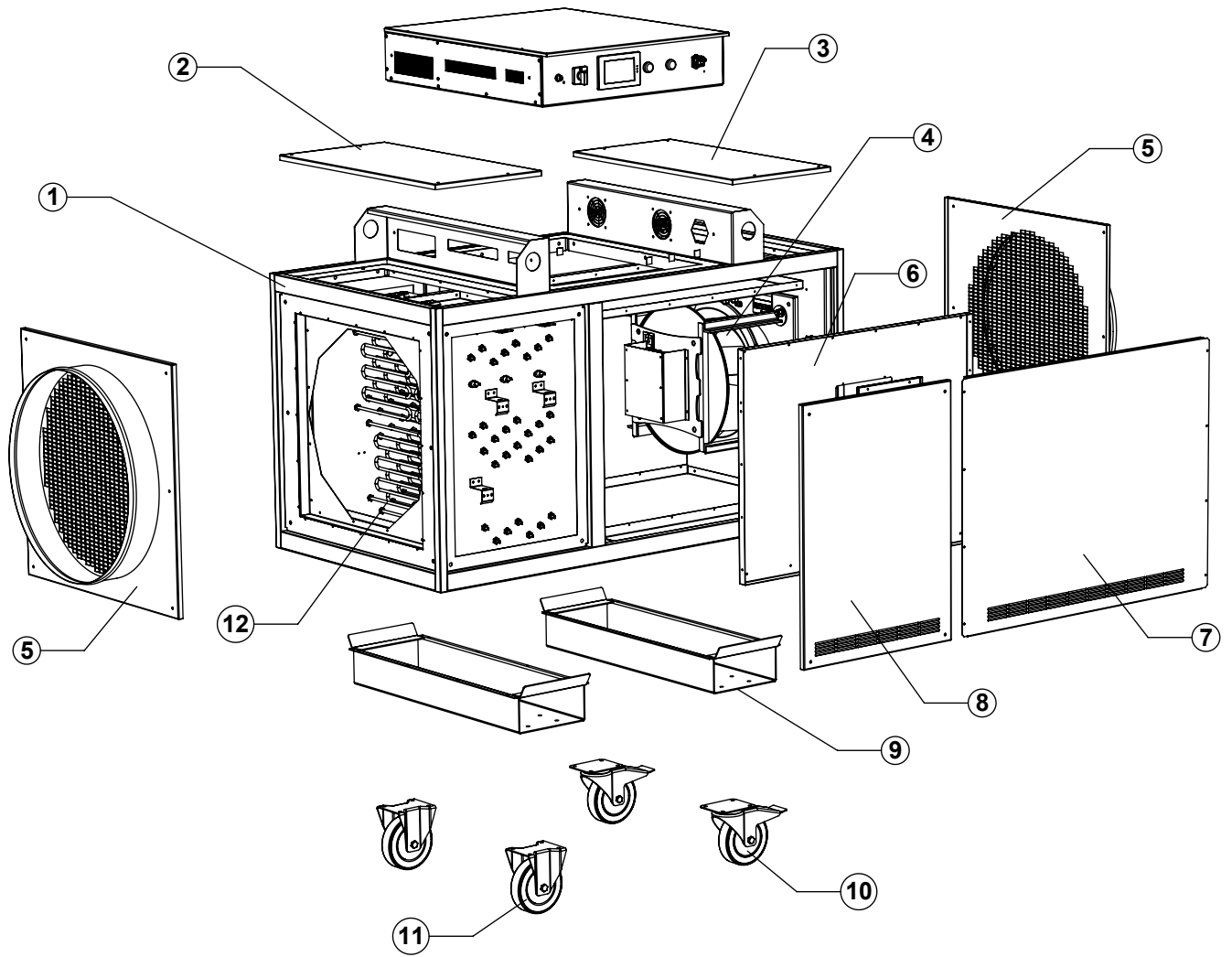

Exploded view cont'd:

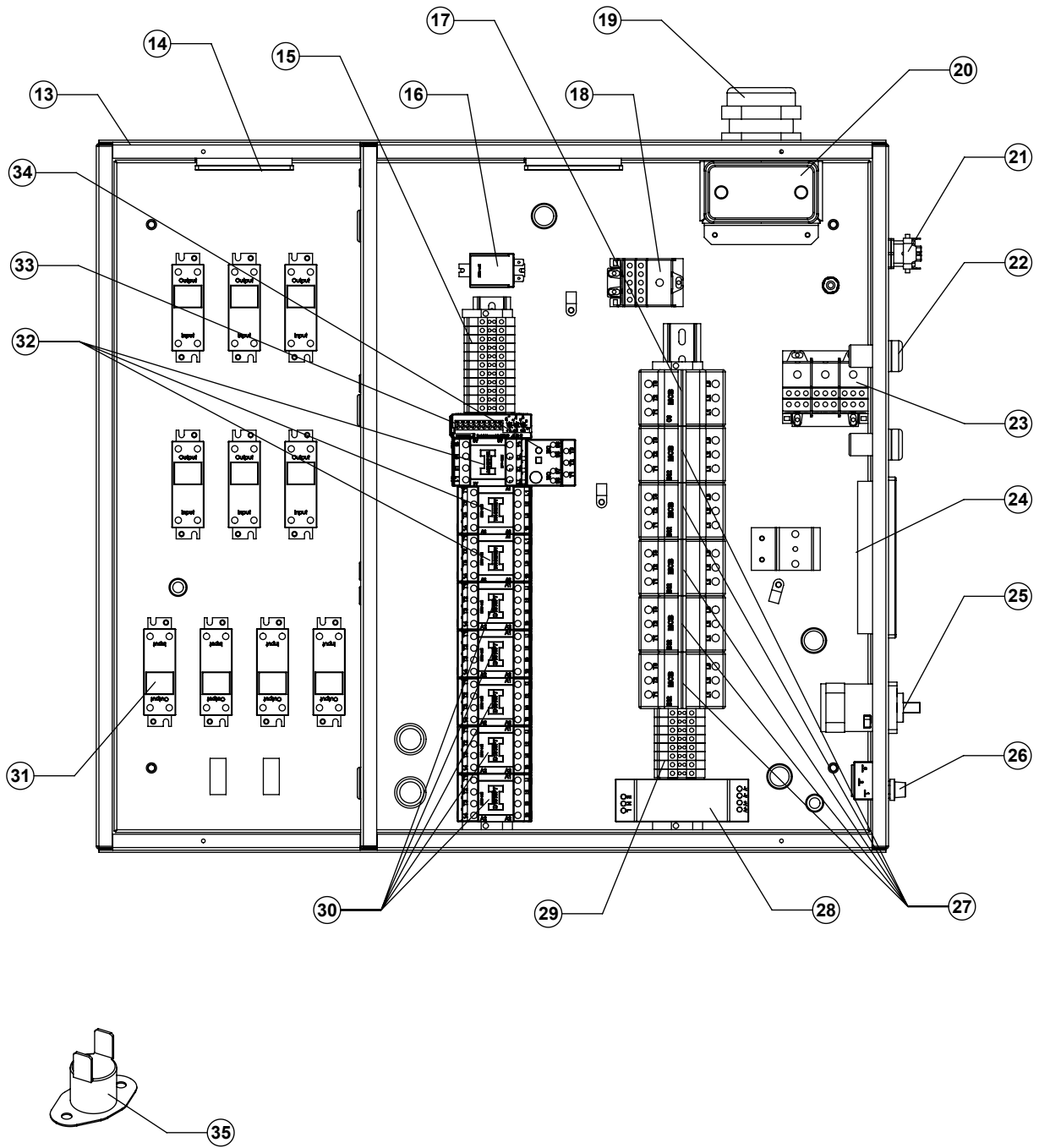

Spare parts:

Drawing No	Description	Part No
1.	Welded frame assembly	BW0202133
2.	Top front panel	BW010217
3.	Top rear panel	BW010218
4.	Fan motor assembly	FA010210
5.	Front/ Rear panel	BW010626
6.	Galvanised metalwork set.	BW040422
7.	Rear side panel	BW010713
8.	Front side panel	BW010317
9.	Forklift pocket	BW040523
10.	160mm locking castor	ME010226
11.	160mm fixed castor	ME010227
12.	Heating element	HE010113
13.	Electrics enclosure metalwork set.	BW040421
14.	Cooling fan.	FA010131
15.	Terminal assembly. 11way. (Including earth terminal)	EL020433
16.	Relay. 230v 30A.	EL030201
17.	MCB. 6A. 3 pole. Type C.	EL010227
18.	Neutral connector block.	EL020434
19.	Cable gland and lock nut. PA6	ME040213
20.	Power lead clamp.	ME040214
21.	Remote thermostat socket.	EL020523
22.	Lamp. 230v. 22.5mm	EL030714
23.	Phase connector block.	EL020435
24.	PLC controller.	EL040138
25.	Rotary switch. 2 position. On/Off.	EL030155
26.	Safety limit thermostat. SPDT.	EL030415
27.	MCB. 32A. 3 pole. Type B.	EL010209
28.	Power supply unit. 230VAC-24DC	EL040139
29.	Terminal assembly. 8 way.	EL020436
30.	Contactora. 18/32A. 230v coil.	EL030814
31.	Solid state relay. 40A	EL030213
32.	Contactora. 9/25A. 230v coil.	EL010232
33.	Phase sequence relay.	EL030216
34.	Fan motor thermal overload. 4-6A	EL010236
35.	70 degree thermal cut-out. N/C.	EL010311
36.	Supply lead with 125A plug. (Not shown)	EL020529
37.	High temperature PT100 probe. (Not shown).	EL040140
38.	Terminal link. (Not shown).	EL020426
39.	DIN rail end stop. (Not shown).	EL020403

Maintenance:

Always isolate the machine from the power supply before carrying out any maintenance.

Fan motors, elements and switch gear are not customer serviceable components. General maintenance should include regular inspection of:

- 1: Mains cable. Check for signs of damage to the insulation. Replace if necessary.
- 2: Air intake & outlet grills: ensure grills are free from accumulated debris, blow out with compressed air if required.
- 3: Fixings: Check all fixings are present and secure.

Maintenance carried out by a competent person:

- 1: Internal cables should be inspected for signs of heat damage and replaced when necessary.
- 2: All cable connections should be regularly checked and tightened. Particular attention should be paid to the connections at the contactors.
- 3: Regularly check the contactors for signs of heat. Replace if necessary.

FAULT	POSSIBLE CAUSE	SOLUTION
NO HEAT OUTPUT.	FANS AND OR HEATING NOT SWITCHED ON.	CHECK ALL SWITCHES ARE ON.
	THERMOSTAT INCORRECTLY SET.	TURN THERMOSTAT ON CONTROLLER.
	POWER SUPPLY INTERRUPTED.	CHECK POWER SUPPLY.
	FAULT STATE HAS ACTIVATED.	CHECK THE CONTROLLER SCREEN FOR ANY FAULT WARNINGS.
	FAULTY CONTACTOR.	CHECK CONTACTOR AND REPLACE IF NECESSARY.
REMOTE THERMOSTAT NOT SWITCHING THE HEATING ELEMENTS	REMOTE THERMOSTAT INCORRECTLY SET	CHECK REMOTE THERMOSTAT SETTING.
	REMOTE THERMOSTAT PLUG INCORRECTLY FITTED	GO THROUGH FITTING STEPS. P15
	REMOTE THERMOSTAT NOT SELECTED AT THE CONTROLLER.	SELECT REMOTE THERMOSTAT SETTING.
SAFETY LIMIT THERMOSTAT HAS ACTIVATED	AMBIENT ROOM TEMPERATURE TOO HIGH	DO NOT OPERATE IN AN AMBIENT TEMPERATURE ABOVE 40°C.
	EXCESSIVE DUCT LENGTH OR POORLY ROUTED DUCTING	SHORTEN DUCT LENGTH OR RE-ROUTE
	FAN MOTOR FAILURE	TEST FAN MOTOR AND REPLACE IF REQUIRED.
	CORRECT SHUTDOWN PROCEDURE NOT FOLLOWED	ALLOW THE MACHINE TO FULLY COOL AND FOLLOW CORRECT SHUTDOWN PROCEDURE. (SEE P9)
	FAILED SAFETY LIMIT THERMOSTAT	THE SAFETY LIMIT THERMOSTAT IS A FAIL-SAFE DEVICE. CHECK THE CAPILLARY TUBE AND BULB FOR SIGNS OF DAMAGE. REPLACE IF REQUIRED.
FAN MOTOR NOT RUNNING.	POWER SUPPLY INTERRUPTED.	CHECK POWER SUPPLY.
	FAN MOTOR OVER HEATED	THE FAN MOTOR HAS A HIGH TEMPERATURE PROTECTIVE DEVICE FITTED INTO THE WINDINGS. ALLOW THE MACHINE TO FULLY COOL AND ATTEMPT TO START.

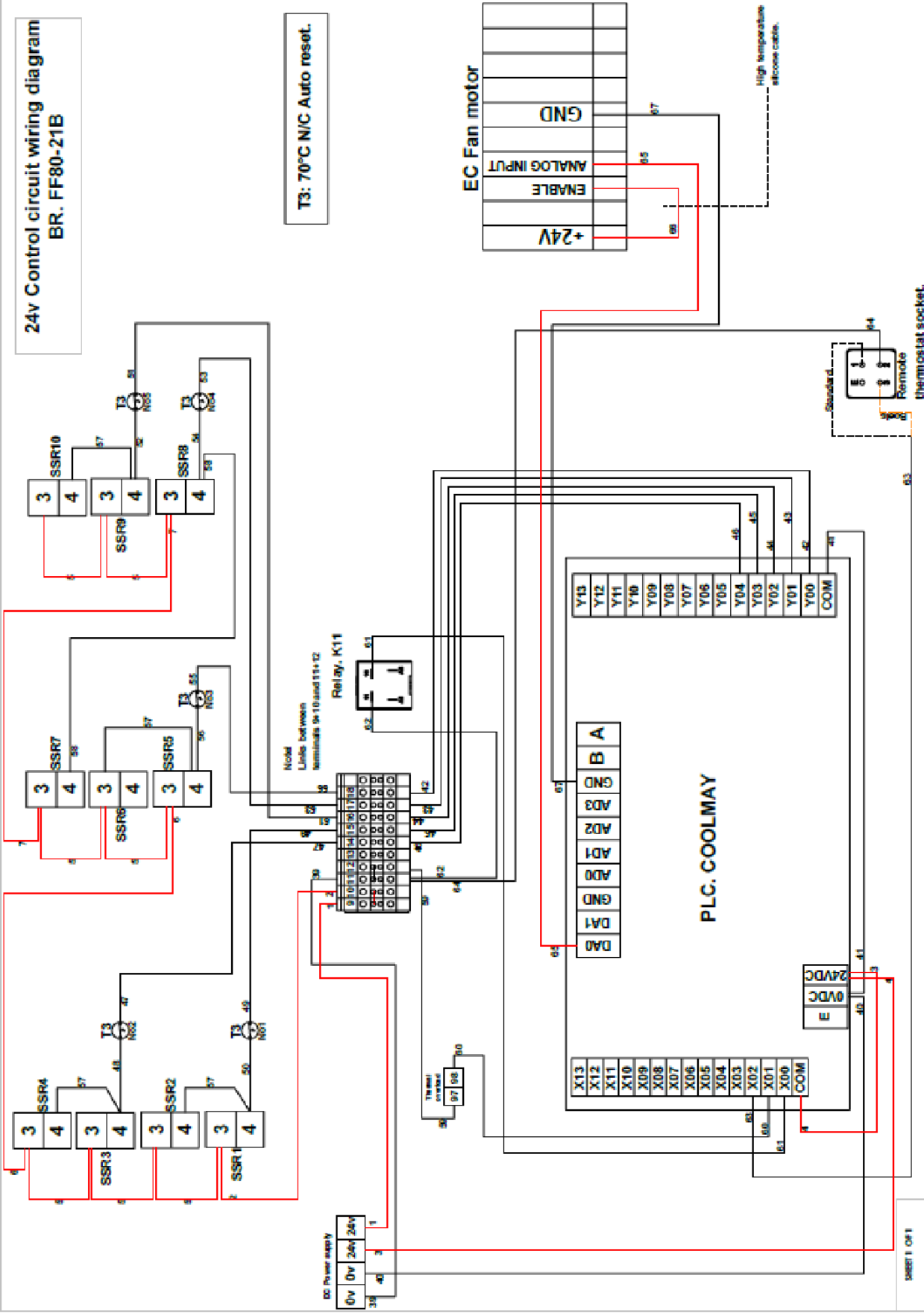

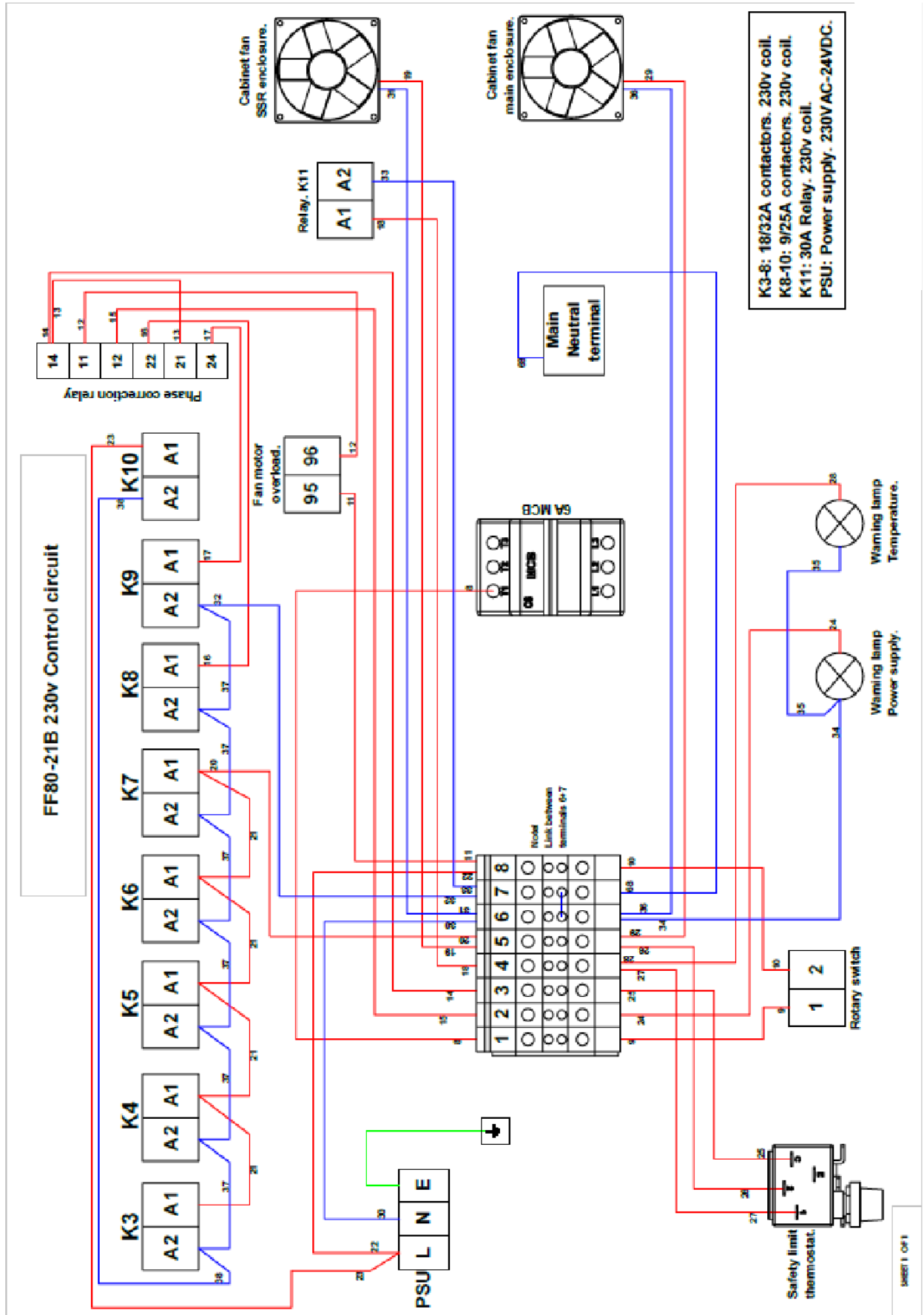

FF80-21B fan motor circuit

Phases 1 & 2 swapped at the rear of K8

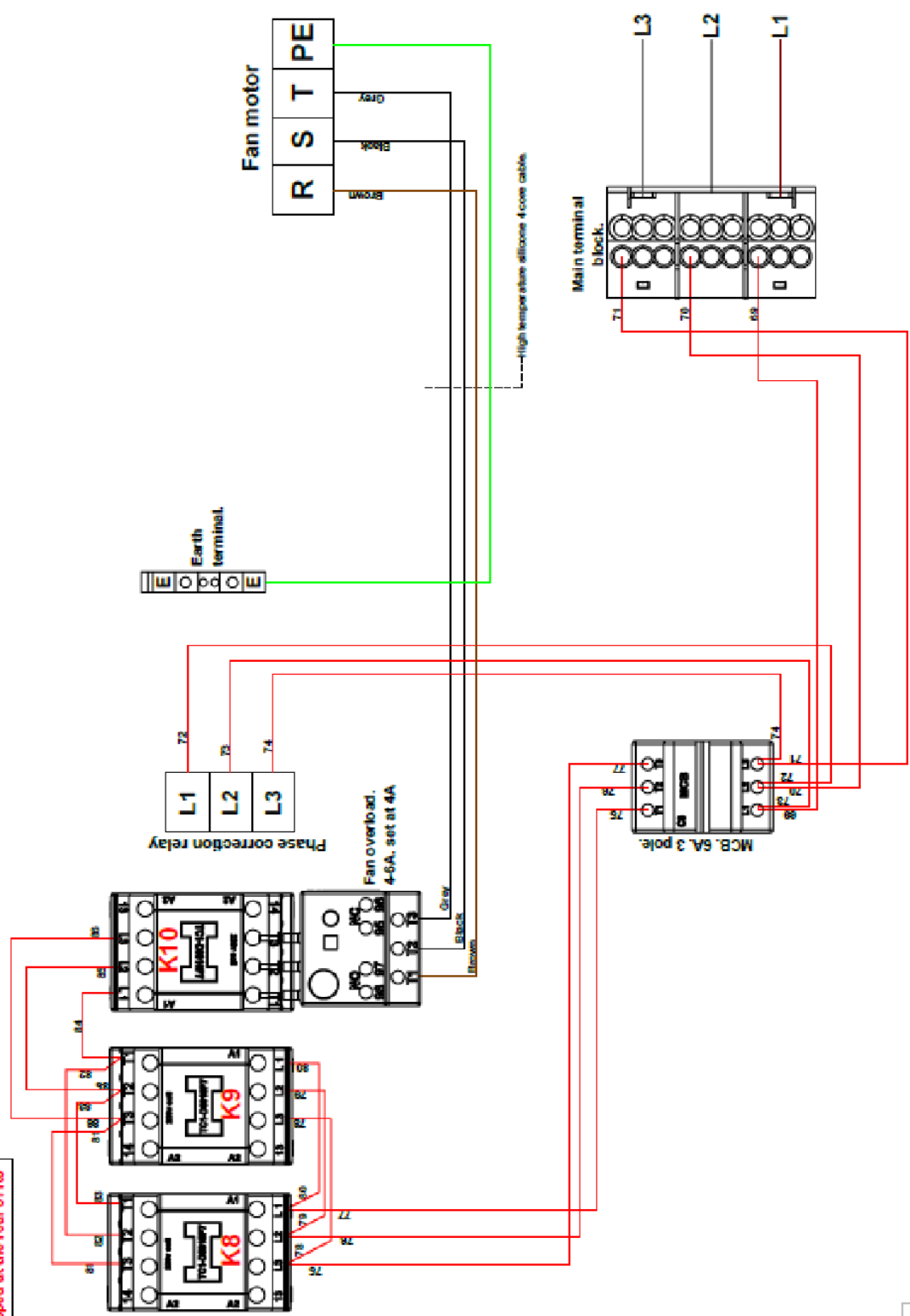

FF80-21 Heating power circuit

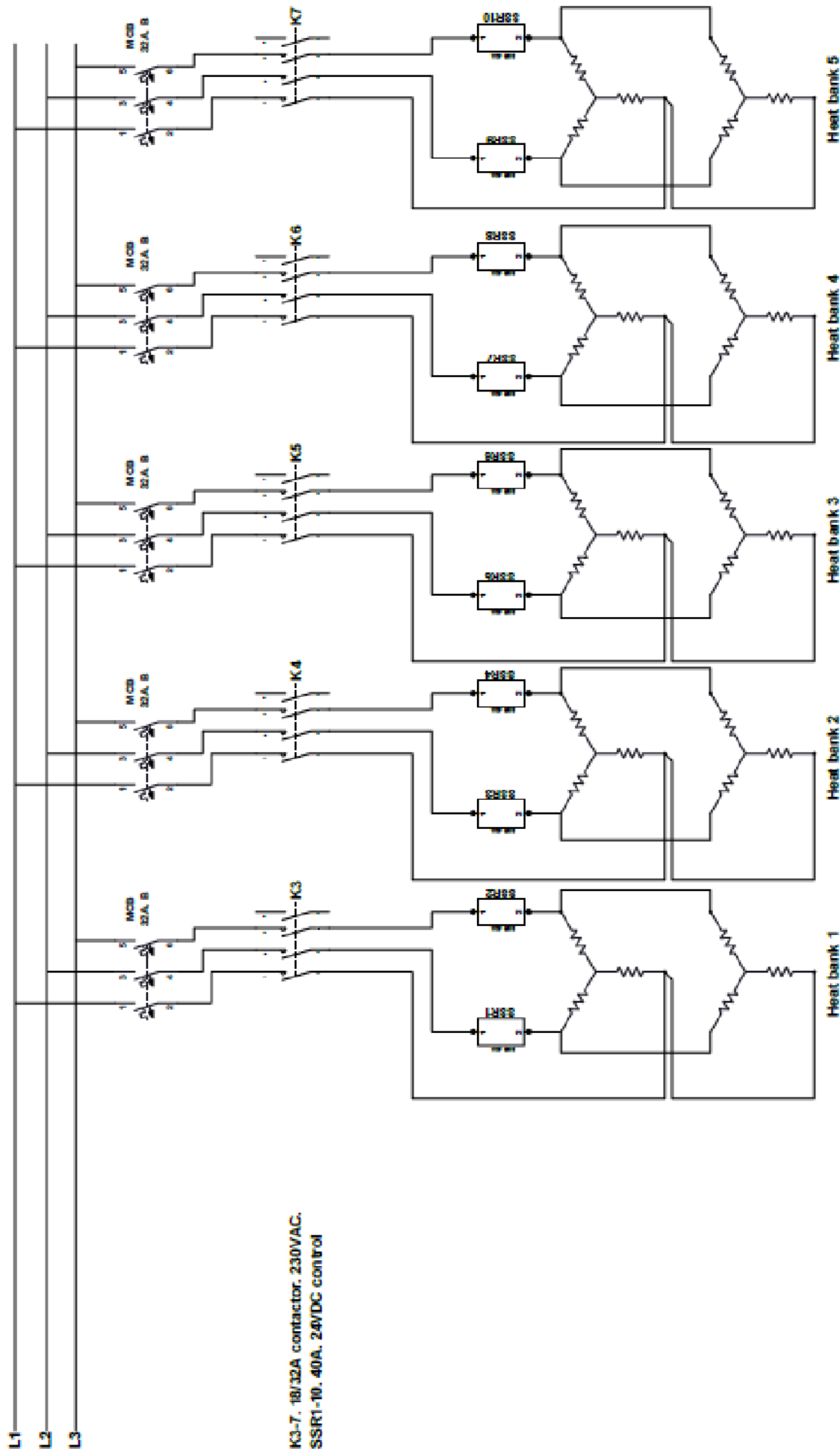

K3-7: 18/32A contactor, 230VAC.
 SSR1-10: 40A, 24VDC control

PLC wiring FF80-21 Coolmay PLC

