

# **WB22-25B/ WB36-25.**

## **ELECTRIC BOILER WITH TOUCH SCREEN CONTROLLER. MANUAL.**

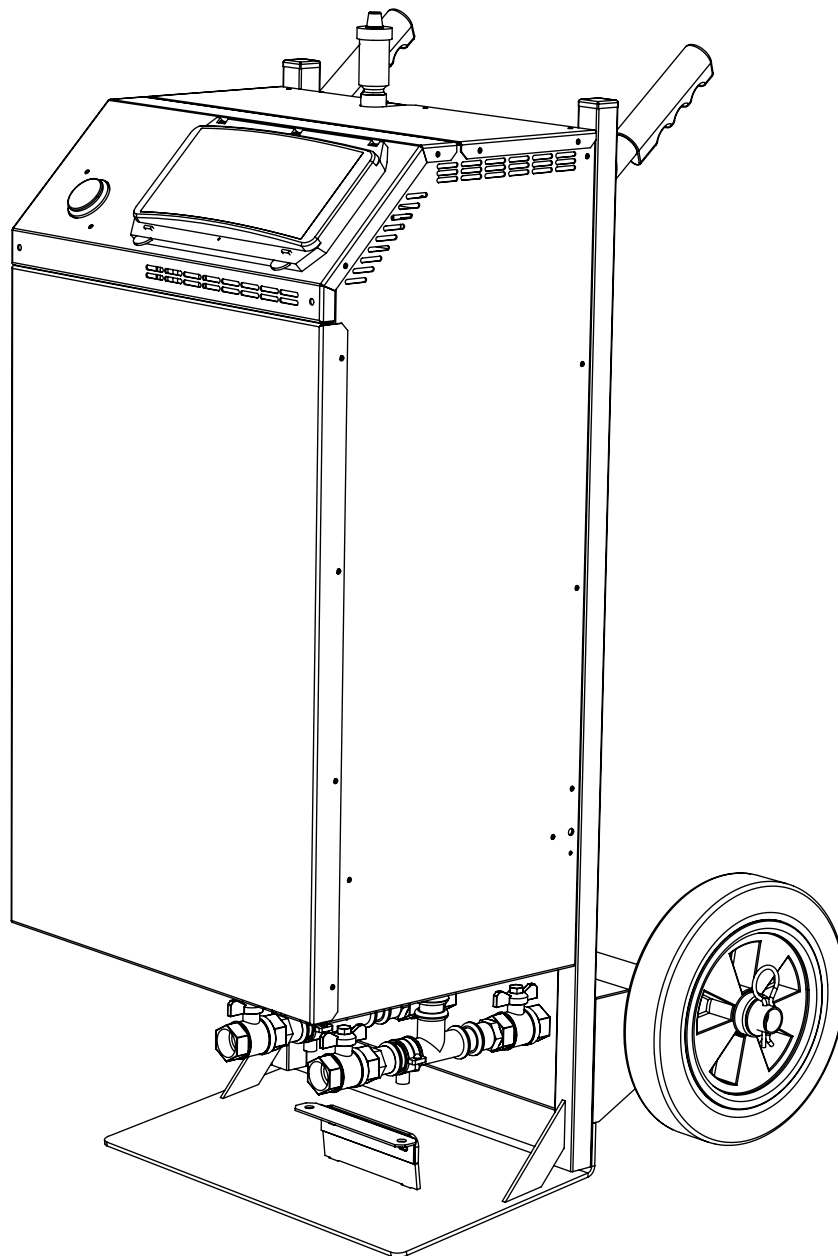

## These instructions should be read by:

The specifying engineer.  
The installation engineer.  
The user.  
The service engineer.



- Any failure to follow these instructions may result in risk of personal injury or damage to the appliance.
- The appliance must be installed and serviced by qualified engineers, in compliance with local regulations.
- Do not switch on if there is a risk that the boiler is frozen.
- The appliance must be switched off and disconnected from its power supply before any work is carried out.
- There are no user controls inside the appliance casing.
- Do not by-pass or over-ride safety devices.
- A copy of these instructions must be provided to the user.
- Do not run the boiler with the hot water inlet and outlet valves closed. This could result in failure of the circulation pump.
- The correct operation of the pressure safety valve must be verified before each installation.
- Risk of scalding. Always allow the boiler to cool before carrying out any work.
- Do not exceed the maximum system capacity.
- Always add a rust inhibitor to the system during each installation. Failure to add an inhibitor could damage the low water pressure switch and shorten the life of the heat exchanger.
- This is a class 1 appliance and must be earthed.

### Specifications:

The WB22 is a 22Kw 3-phase portable electric boiler. It is connected to the power supply with a 3P+N+E 32A plug.

The WB36 is a 36Kw 3-phase portable electric boiler. It is connected to the power supply with a 3P+N+E 63A plug.

The heat exchanger is of a welded mild steel construction and has been hydraulically tested to 4 bar.

The boiler can be connected to a heating system without the need for a feed and expansion system.

Maximum system capacity 160 Litres.

The appliance comes complete with: 10 Litre expansion vessel, circulation pump, pressure gauge, touch screen controller, safety valve, low water pressure switch, safety limit thermostat and control switches.

The boilers are suitable for connection to most heating systems with a maximum working pressure of 3 bar and a maximum working temperature of 80°C.

# Contents





- **Warnings-----P2**
- **Technical specifications-----P4**
- **General description-----P5**
- **Connecting the boiler to a standard heating system-----P6-8**
- **Connecting the boiler to a floor drying system using  
the optional rear heat exchanger.-----P9-10**
- **Safety devices-----P10-11**
- **Starting the boiler,boiler controller and standby mode-----P12-13**
- **Manual/ standard heating operation-----P14-16**
- **Heater protocols. Overview-----P17**
- **Creating and saving a protocol-----P18-19**
- **Running a protocol-----P21-23**
- **Deleting a protocol-----P20**
- **Frost protection-----P24**
- **Machine settings-----P25-27**  
Trim.  
Frost protection.  
Change user password.
- **Changing the time and date-----P27**
- **Fault screens-----P28-29**
- **Cleaning and maintenance-----P30**
- **Fault finding-----P31**
- **Spare parts-----P32-34**
- **Wiring diagrams-----P35-38**
- **Pump curves, settings and fault codes-----P39**

<b>TECHNICAL SPECIFICATIONS. WB22-25B</b>	
Heating capacity.	21 kw
Power supply.	400v. 3P+N+E. 32A. 50Hz.
Maximum running current. (400V)	30.5A
Water flow. Max.	27 L/min
Weight. (Dry/wet)	64 kg/ 79 kg
Noise level at 3m.	<32 dB(A)
IP Rating.	IP20
Maximum ambient operating temperature.	35 °C +/- 3°C
Maximum system capacity.	160ltr
Dimensions H/W/D	1017/611/599mm

<b>TECHNICAL SPECIFICATIONS. WB36-25</b>	
Heating capacity.	36 kw
Power supply.	400v. 3P+N+E. 63A. 50Hz.
Maximum running current. (400V)	53A
Water flow. Max.	27 L/min
Weight. (Dry/wet)	64 kg/ 79 kg
Noise level at 3m.	<32 dB(A)
IP Rating.	IP20
Maximum ambient operating temperature.	35 °C +/- 3°C
Maximum system capacity.	160ltr
Dimensions H/W/D	1017/611/599mm

### Standards applied:

BE EN 12100. 2010.  
 BS EN 60335-1. 2012.  
 BS EN 60335-2. 2009.  
 BS EN 61000.

<b>MACHINE AND INSTRUCTION ICONS</b>	
	Important information
	Risk of electric shock. Isolate from power supply before removing cover.
	Main power on/off switch
	Always read the manual before operating.
	Warning. To avoid overheating do not cover the appliance.

## General description:

The WB22/36 electric boiler has been developed for heating and screed/ floor drying applications.

The controller incorporates an embedded microprocessor and resistive colour touch screen. A specially developed application allows for manual and automatic control with power modulation to maintain accurate temperature control.

### Features include:

- Password protection to prevent tampering during critical applications.
- Optional frost protection to prevent the boiler freezing when not operating.
- A clear and simple programming system that requires minimal training.
- Temperature probe failure warning.
- Power failure back up. In the event of a power failure the machine will store it's current position in a program and then will continue from this point once power is restored.

The controller is located on the front of the machine and is protected by a polycarbonate inspection window.

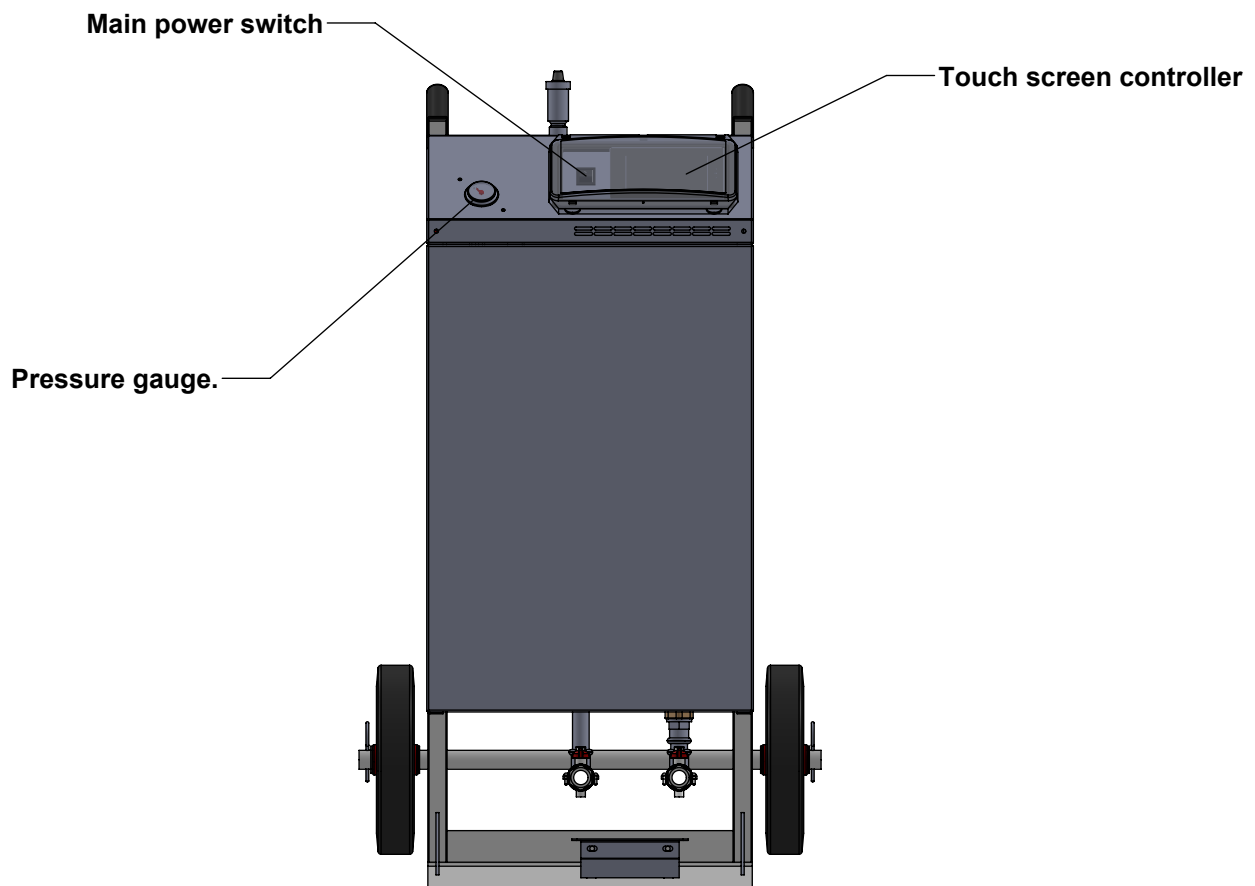

## Connecting the boiler to a standard heating system:

The WB22-25 and WB36-25 is supplied with 3/4 inch BSPF female fittings to the front of the machine for connection to a heating system. Shut off valves and automatic air-bleeds are supplied as standard.

WB22 hydraulic diagram.  
Heating system.

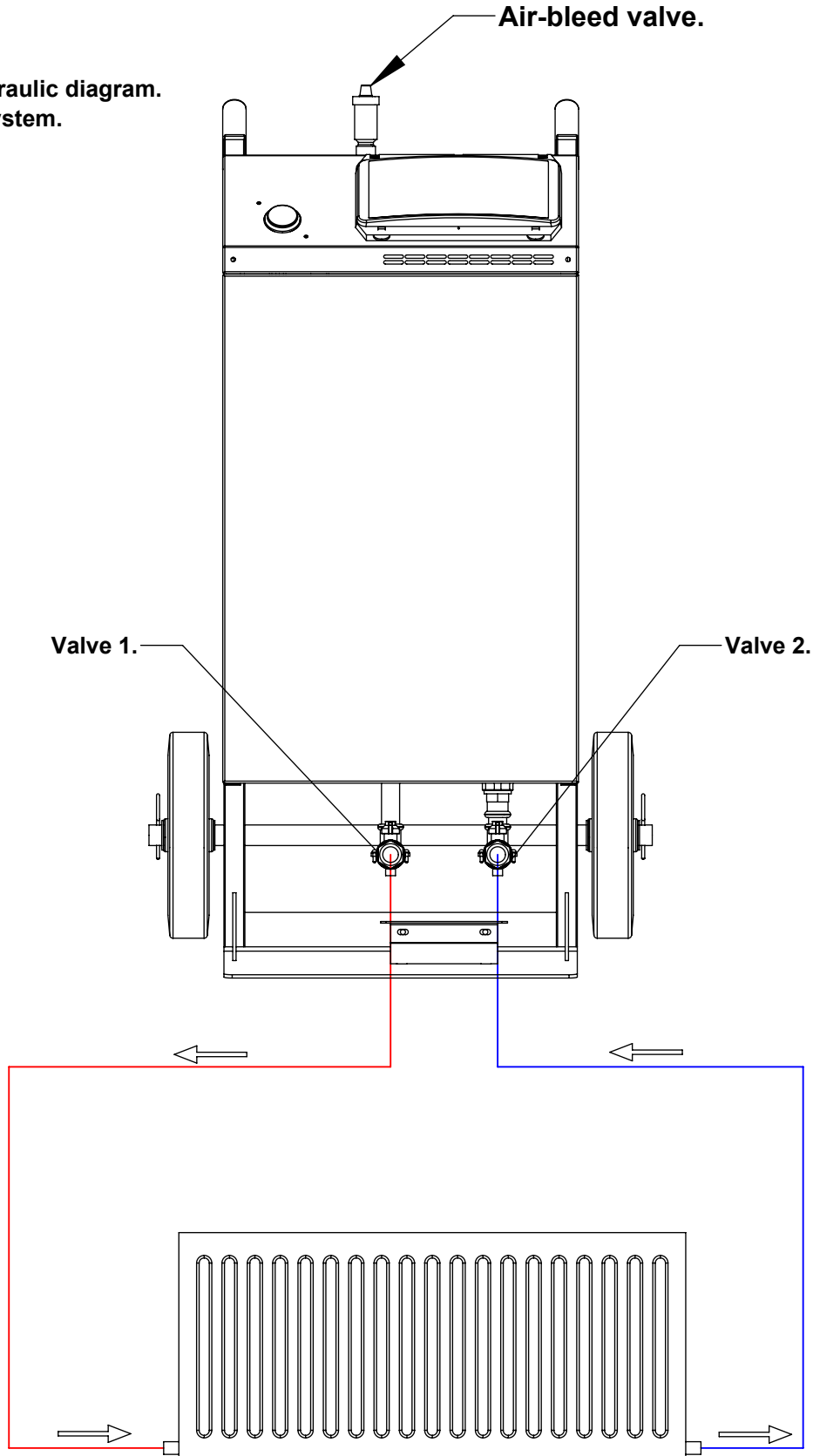

# Hydraulic connections and valves:

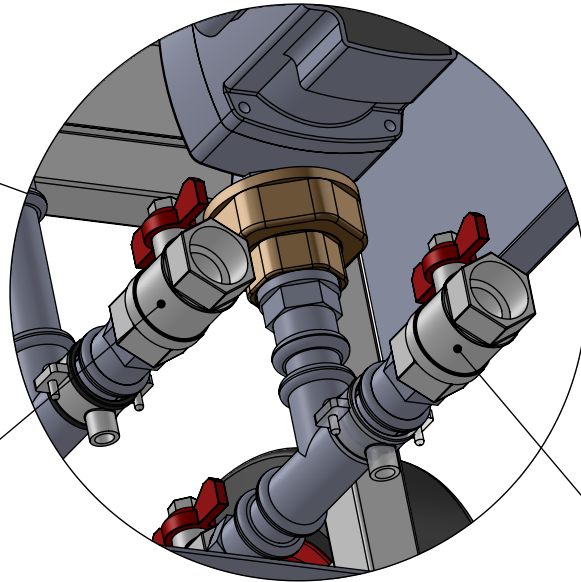
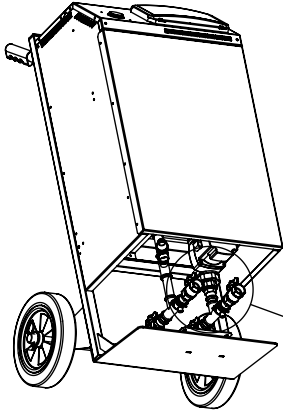

Valve 1.

Valve 2.

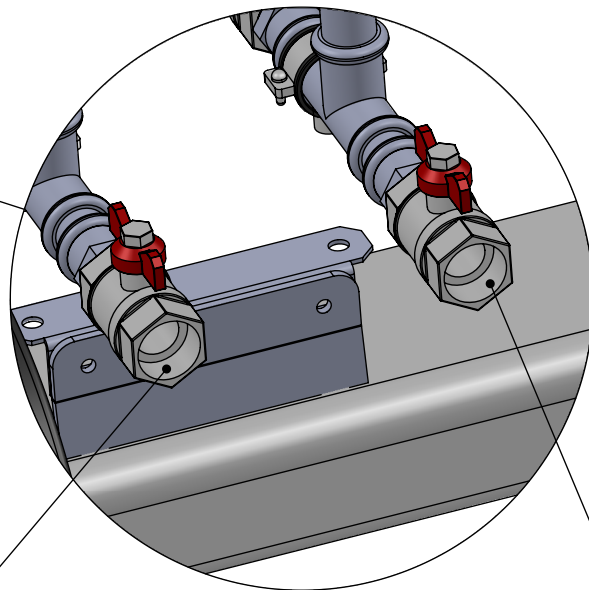
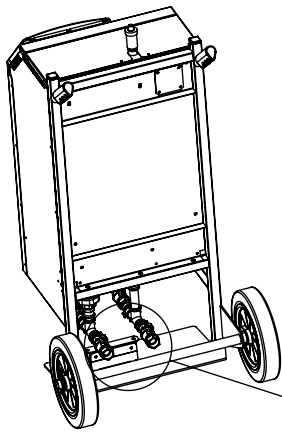

Valve 3.

Valve 4.

## Connecting the boiler to a standard heating system cont'd:

An inhibitor should always be used when refilling a system. Failure to use an inhibitor will shorten the life of the main heat exchanger and low pressure switch.

- 1: Connect the boiler to the heating system (See P6).
- 2: Open valves 1&2,. Loosen the air-bleed caps on the air bleed (See P6).
- 3: Connect a mains water feed to valve 3. This is a standard 3/4 inch BSPP fitting (See P7).
- 4: Open the filling valve and pressurise the system to between 1.5-2 bar. Shut off the valve 3.

1.5-2 bar.



Boiler pressure gauge.

5: Check the system for leaks.

6: The boiler is now ready for use.

# Connecting the boiler to a floor drying system.

WB22/36 hydraulic diagram.  
floor drying system.

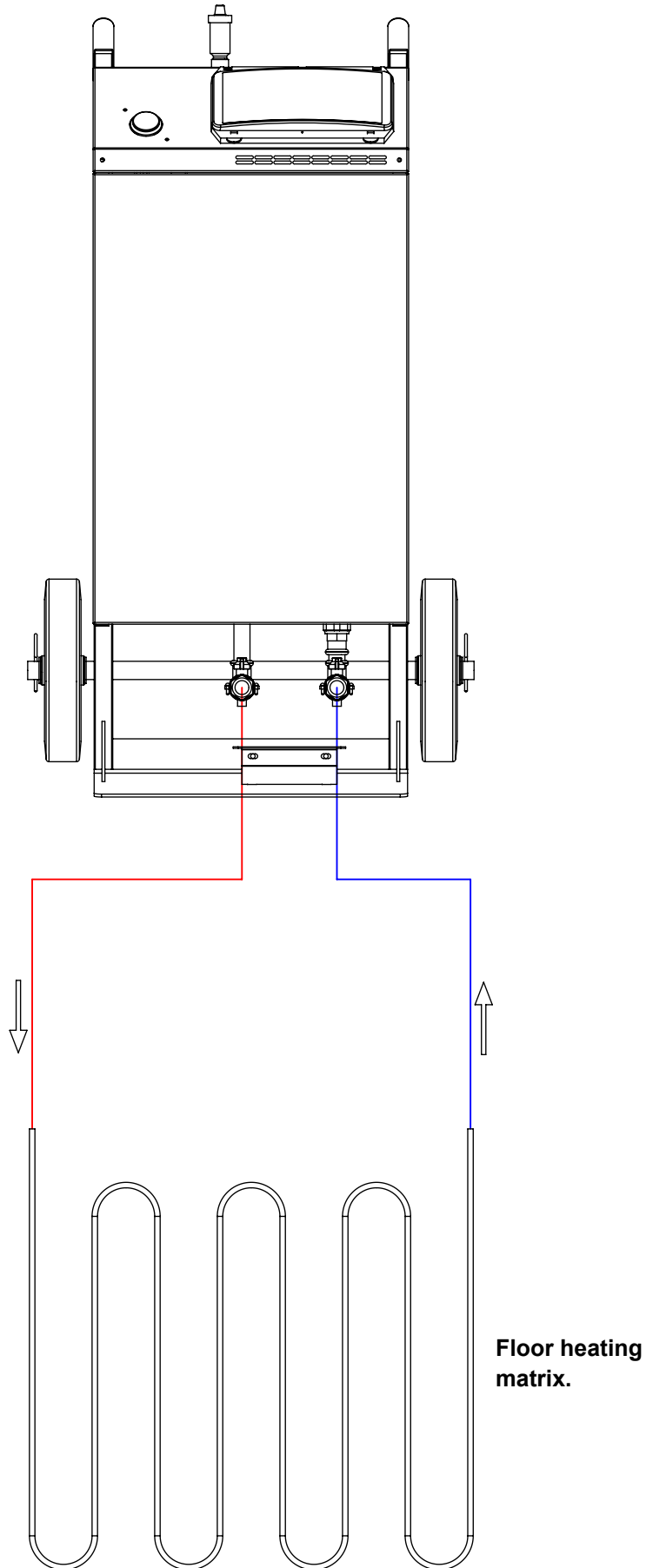

## **Connecting the boiler to a floor drying system.**

The WB22-25 and WB36-25 have been specifically designed for floor drying applications.

An inhibitor should always be used when refilling a system. Failure to use an inhibitor will shorten the life of the main heat exchanger and low pressure switch.

- 1: Connect the boiler to the floor drying system (See P9).**
- 2: Open valves 1&2. Ensure valves 3&4 are closed (See P7).  
Loosen the air-bleed caps on the automatic air bleed (See P6).**
- 3: Connect a mains water feed to valve 3. This is a standard 3/4 inch BSPP fitting (See P7).**
- 4: Open valve 3 and pressurise the system to between 1.5-2 bar. Shut off the valve 3.**
- 5: Check the system for leaks.**
- 6: The boiler is now ready for use.**

### **Safety devices:**

The boiler is fitted with four safety devices. These must not be by-passed or disabled at any time:

- **Pressure relief valve:** Should the system pressure rise above 3bar the pressure relief valve on the bottom of the boiler will open and drain the water. In this instance please contact your installer. (see P11)
- **Low water pressure switch:** to prevent the boiler operating with insufficient water a low water pressure switch is fitted. Should the water pressure fall below approximately 0.8 bar this switch will activate a warning lamp and shut the system down.
- **Manual reset safety limit thermostat:** Should the temperature of the boiler rise above 90°C the safety limit thermostat will activate a warning lamp and shut the system down. In this instance please contact your installer. (See P11)
- **Fail-safe contactor.** In the event of a control contactor failure the fail-safe contactors will ensure safe disconnection of the power from the heating elements.

## Safety devices cont'd:

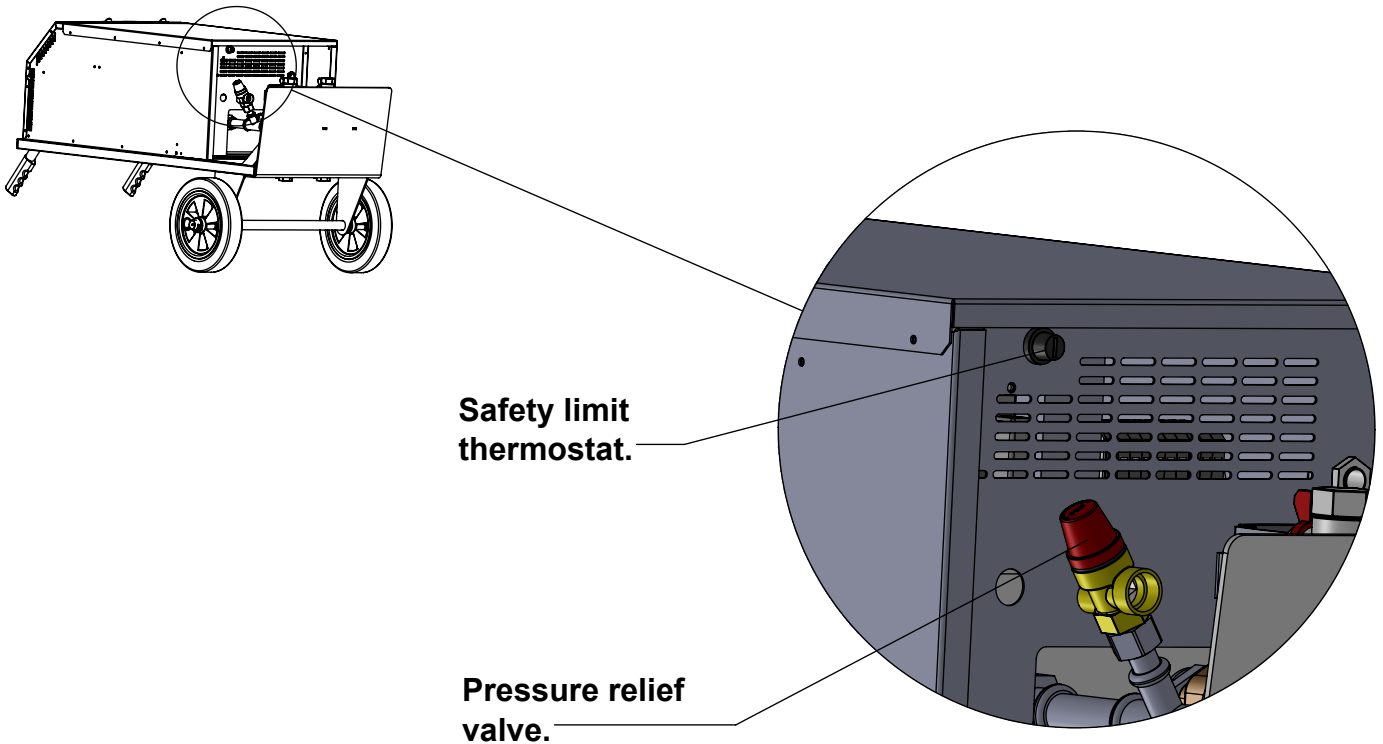

### Checking and resetting the safety limit thermostat:

Should the safety limit thermostat activate the causes should be investigated.

- Remove the black plastic screw cover from the safety limit thermostat.
- If the reset button is noticeably pronounced the reset has activated.
- To reset the thermostat press the reset button. Allow the machine to fully cool down before resetting. Due to high levels of insulation on the main heat exchanger it may take a considerable time for the boiler to cool.
- Always replace the screw cap after resetting.

### Pressure relief valve:

Correct operation of the pressure relief valve should be verified before each installation.

- Ensure the machine is cool and disconnected from the power supply. Ensure the water pressure is between 1.5-2 bar.
- Turn the red knob at the front of the valve clockwise through 30 degrees. pressurised water should exit through the valve.

## Starting the boiler, boiler controller and standby mode:

- Connect the machine to a suitable power supply. See P4.
- Turn the main power switch to I. (See P5)
- There will be a short delay as the controller powers up.
- The controller enters standby mode and displays the home screen.
- The circulation pump will run. (If ECO mode is off)

### Home screen. Standby mode.

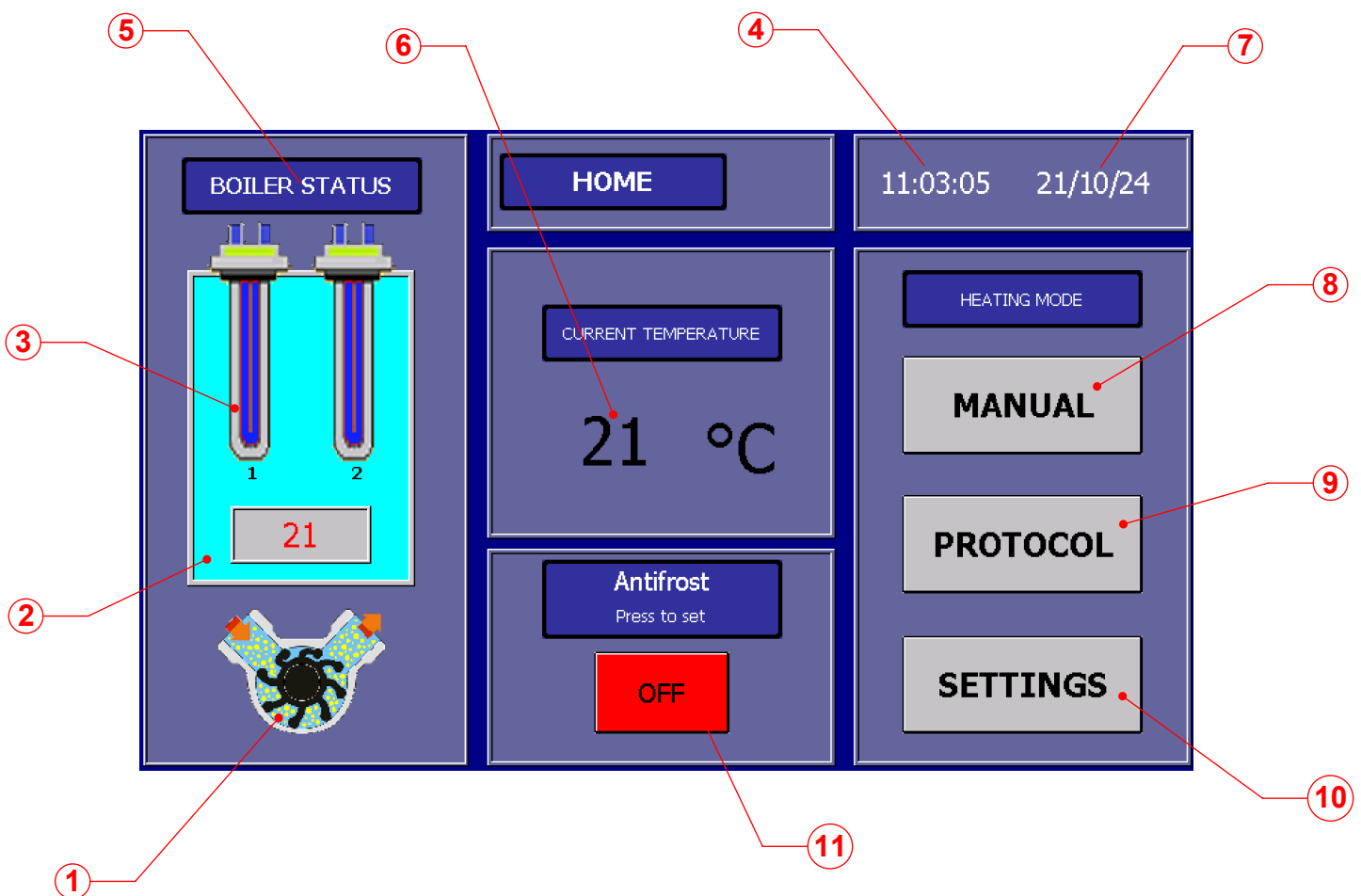

During standby mode the circulation pump will operate. All heating is inactive unless frost protection has been set to ON.

## **Home screen icon descriptions:**

- 1: Circulation pump status indicator. An animated pump symbol indicates the pump is running.**
- 2: Main heat exchanger status indicator. Blue indicates no current heating process. Orange indicates heating in progress.**
- 3: Heating element status indicator. There are two banks of heating elements fitted to the WB22 and WB36. Each operates independently. Blue indicates element bank inactive. Red indicates element bank active.**
- 4: Displays the current time. Hrs/Mins/Sec.**
- 5: Displays the current status of the machine.**
- 6: Displays the current temperature of the fluid in the main heat exchanger.**
- 7: Displays the current date. dd/mm/yyyy.**
- 8: Touch screen button for manual (Standard heating) mode.**
- 9: Touch screen button for heating protocol (Heating program mode).**
- 10: Touch screen button for controller settings.**
- 11: Touch screen button to activate frost protection.**

## Manual/ standard heating operation:

To access manual heating mode:

1: Press the manual touch button on the home screen. A password is required to access manual mode. (If password protection has been activated).

2: The password screen will be displayed.

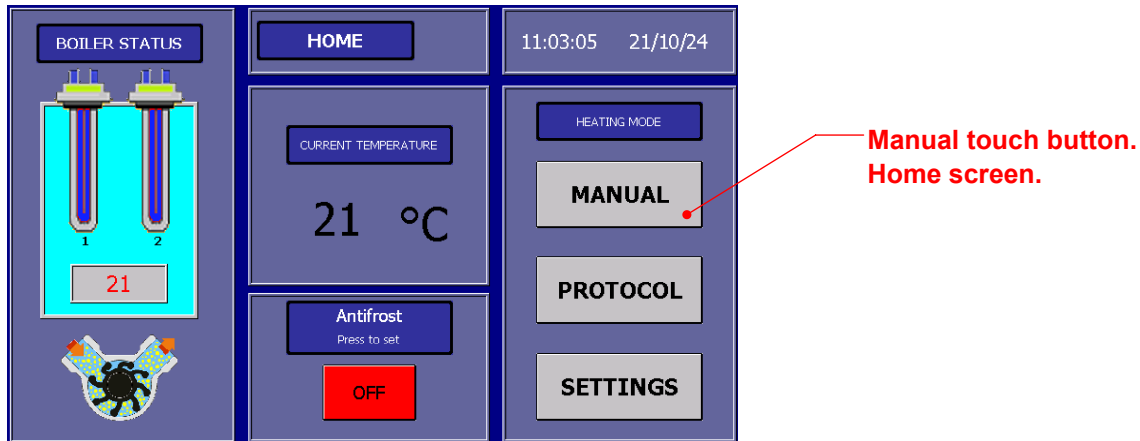

## Password screen:

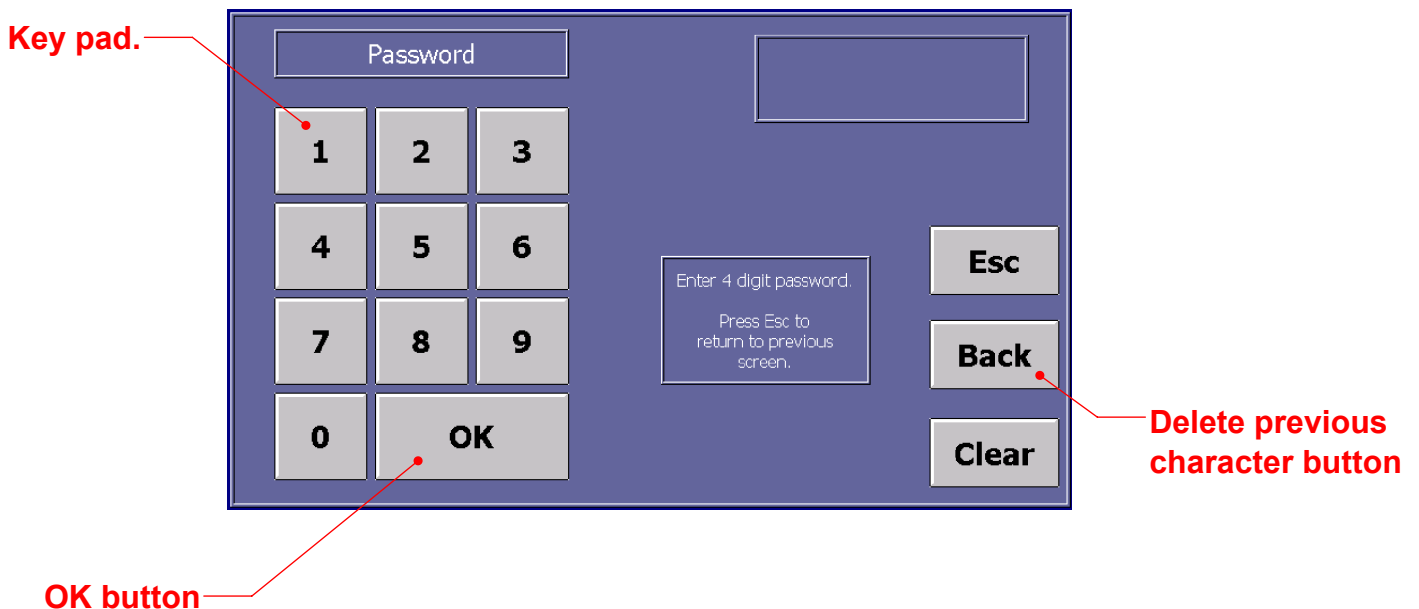

3: Use the key pad to enter the current 4 digit password. Press the OK button. The factory set password is 1234.

4: The manual mode screen will be displayed.

## Manual mode screen:

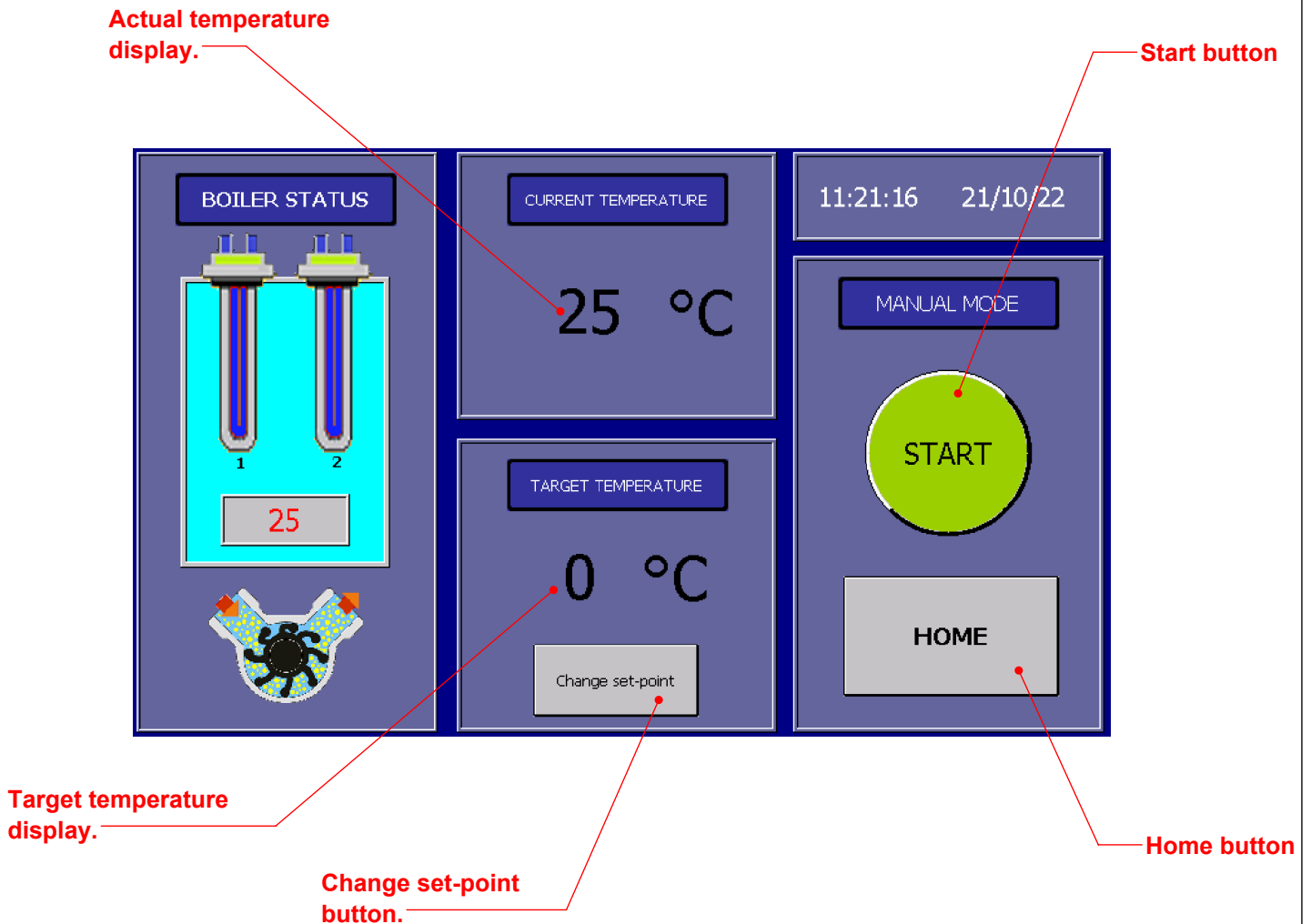

- 5: Set the desired temperature using the Change Set-point button on the manual mode screen. The maximum target temperature is 80 °C. A key pad will appear. Enter the desired temperature and press OK.
- 6: Press the start button to begin the heating process.
- 7: The Home button can be used to return to the home screen. This is not active when the Start button is in the ON position.
- 8: The heating status indicators will change colour to show that heating is in progress. It should be noted that as the temperature nears the target temperature these will switch in and out. If the unit rises above the target temperature both elements will switch out and the heat exchanger indicator will turn blue. As the temperature falls the elements will switch back in.

Heating status indicators.

Stop button.

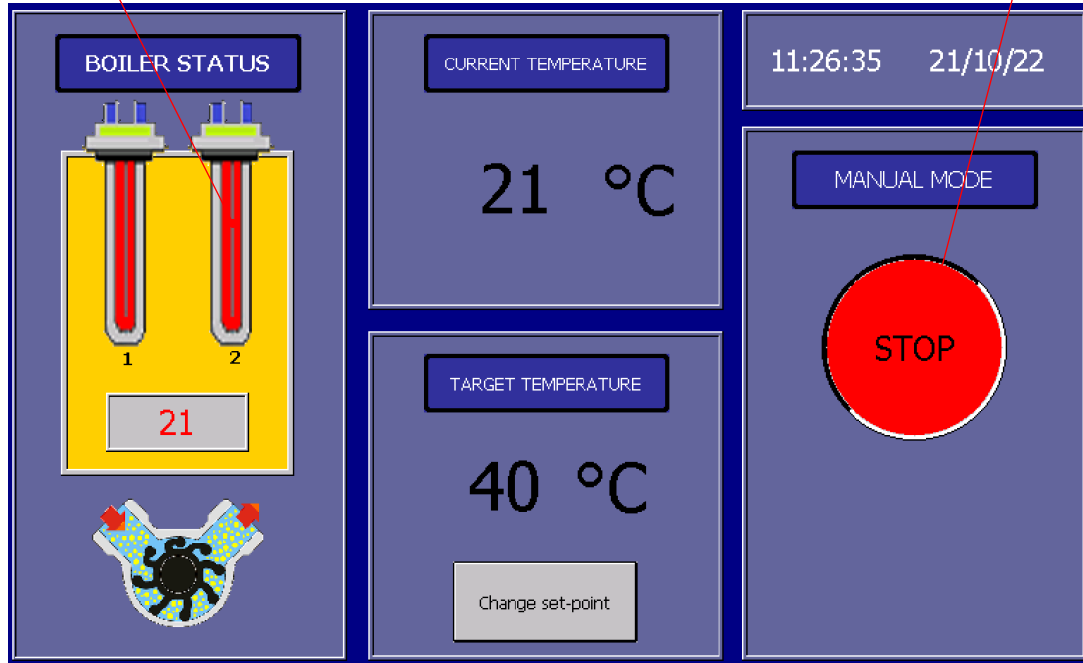

**9: The heater will run indefinitely in manual mode until the heating process is stopped.**

**10: The target temperature can be altered in real time as the boiler is heating.**

**11: To stop the heating process press the stop button.**

**12: The controller will return to the previous screen.**

**13: Press the Home button to return to the Home screen.**

## Heater protocols. Overview:

Unlike domestic boilers that may use a 7 day programmable timer the WB22 and WB36 use a protocol programming system specifically designed for screed/floor drying applications.

It can be used as a simple timer also.

The protocol system is programmed in time and temperature steps. There can be up to 27 steps in a single protocol. Up to 5 protocols can be saved to the control unit at any one time. Each being allotted a number from 1-5.

### Example protocol:

Protocol 1 viewer								
	°C	HRS		°C	HRS			
Step 1	35	10	Step 10	0	0	Step 19	0	0
Step 2	45	9	Step 11	0	0	Step 20	0	0
Step 3	50	12	Step 12	0	0	Step 21	0	0
Step 4	55	5	Step 13	0	0	Step 22	0	0
Step 5	0	0	Step 14	0	0	Step 23	0	0
Step 6	0	0	Step 15	0	0	Step 24	0	0
Step 7	0	0	Step 16	0	0	Step 25	0	0
Step 8	0	0	Step 17	0	0	Step 26	0	0
Step 9	0	0	Step 18	0	0	Step 27	0	0

Protocol 1 viewer

Back

In the above sample the 27 steps can be seen, although only 4 have been used.

If this protocol was run it would do the following:

Step1 would have a target temperature of 35 degrees for a period of 10 hours.

It would then automatically move to step 2 with a target temperature of 45 degrees for 9 hours and so on until the protocol had completed.

All heating would then stop. (unless frost protection was ON). The circulation pump would continue to run. (If the machine is not set to ECO mode).

The temperature column is in degrees centigrade and the time column in hours.

# Creating and saving a protocol:

1: Return the controller to standby mode and the home screen.

Home screen.

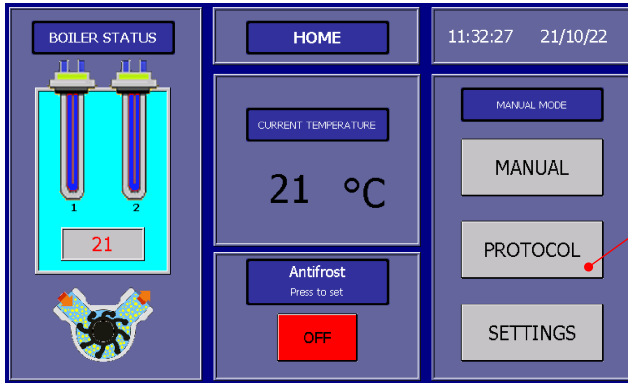

Protocol button.

2: Press the Protocol button. This will take you to the password screen. (If password protection is activated).

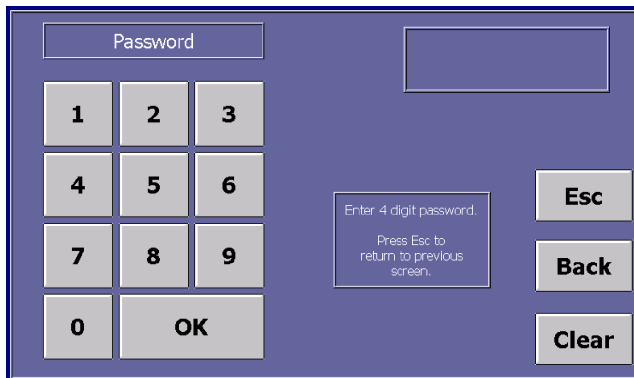

3: Enter the password (See P14). This will take you to the Protocol Menu screen.

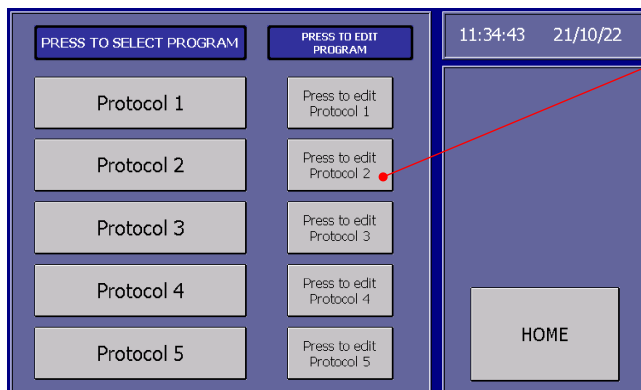

Edit protocol buttons.

4: Press the Edit Protocol button. This will take you to the Protocols Edit screen.

## Heating Protocols screen.

Protocol 1. Edit screen 1. 11:36:49 21/10/22

PRESS TO CHANGE SETTING

	STEP 1	STEP 2	STEP 3	STEP 4	STEP 5	STEP 6	STEP 7	STEP 8	STEP 9
°C →	35	45	50	55	0	0	0	0	0
HRS →	10	9	12	5	0	0	0	0	0

BACK

Please note!  
All settings must run concurrently and start at step 1.  
Any zeros will stop the program.

Move to steps 10-18

Protocol steps

Temperature edit buttons.

Hours edit buttons.

Move to next page button.

Back button.

5: The protocol edit menu consists of 3 pages. Each page has 9 steps listed. There are 27 steps in total.

6: Press the Temperature edit buttons and Hours edit buttons to enter the desired settings into the program. A keypad will appear. Temperature has a maximum setting of 80°C and Hours has a maximum setting of 99. The program must start at step 1 and run concurrently. Any zeros will stop the program at that point.

Number Input

55

max.: 80  
min.: 0

7	8	9	Clear
4	5	6	Esc
1	2	3	Back
.	0	-	OK

Enter the desired setting and press OK.

7: To move to the next page press Move to next page button.

8: Once the programming is complete press the Back buttons to return to the Protocol menu page. The program is automatically saved.

## To delete a protocol:

1: To delete a protocol go to page 3 of the protocol edit screen.

Protocol 1. Edit screen 3. 12:11:14 21/10/22

PRESS TO CHANGE SETTING

	STEP 19	STEP 20	STEP 21	STEP 22	STEP 23	STEP 24	STEP 25	STEP 26	STEP 27
°C →	0	0	0	0	0	0	0	0	0
HRS →	0	0	0	0	0	0	0	0	0

BACK

Please note!  
All settings must run concurrently  
and start at step 1.  
Any zeros will stop the program.

Clear All settings

Clear all settings button.

2: Press the Clear all settings button. This will zero all settings for that program.

3: Press the Back buttons to return to the protocol menu screen.

## Running a protocol from memory:

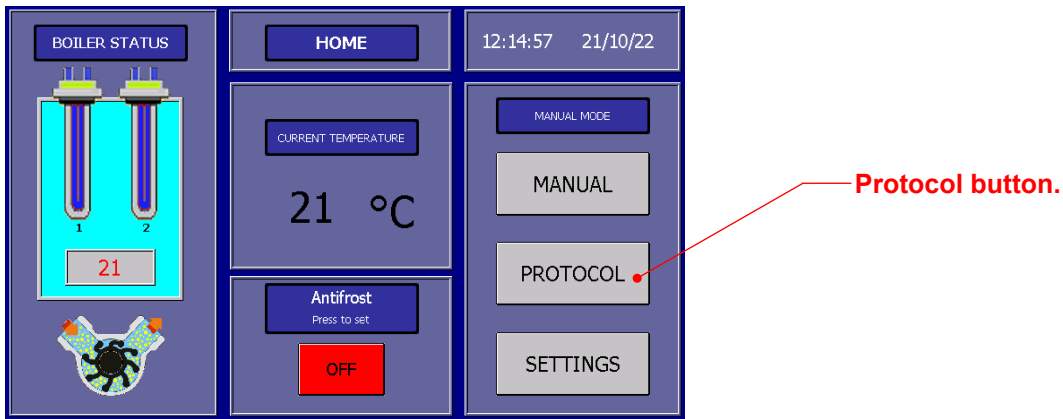

**1: Return to the Home screen and press the Protocol button. You will be prompted to enter the password. (See P14). (If password protection has been activated).**

**2: Once the password has been entered you will be taken to the Protocol menu screen.**

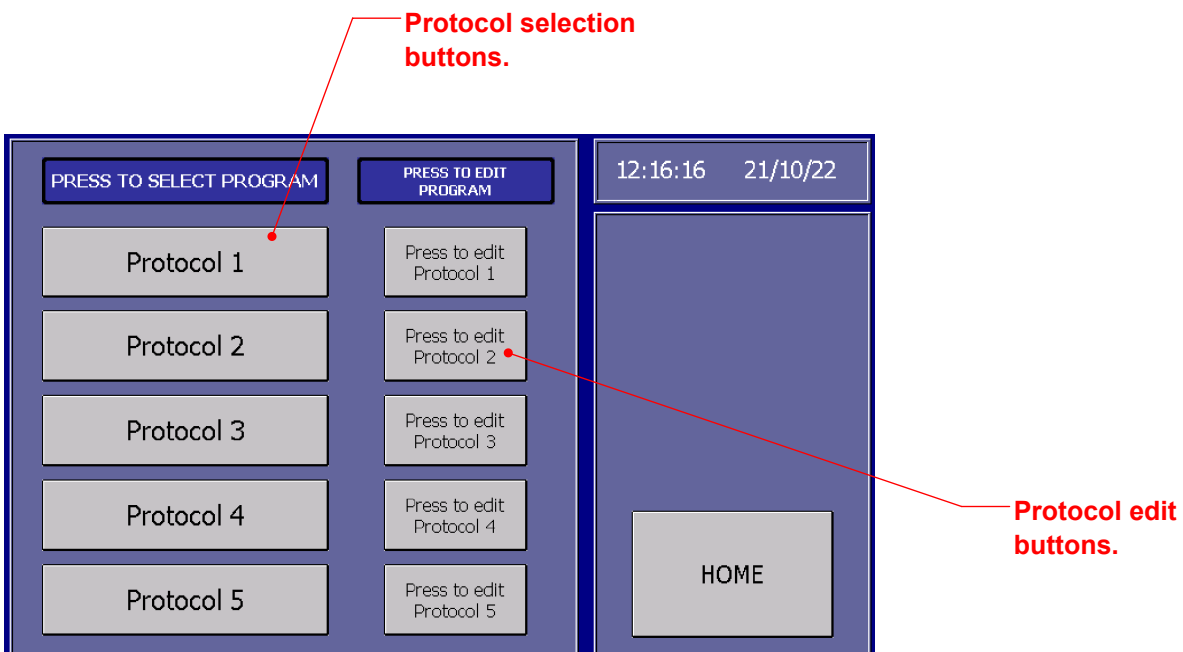

**3: Choose the required Protocol from the menu. This will take you to the protocol run screen.**

**4: You can preview the program by pressing the Protocol edit button and scrolling through the program.**

## Running a protocol from memory con'd:

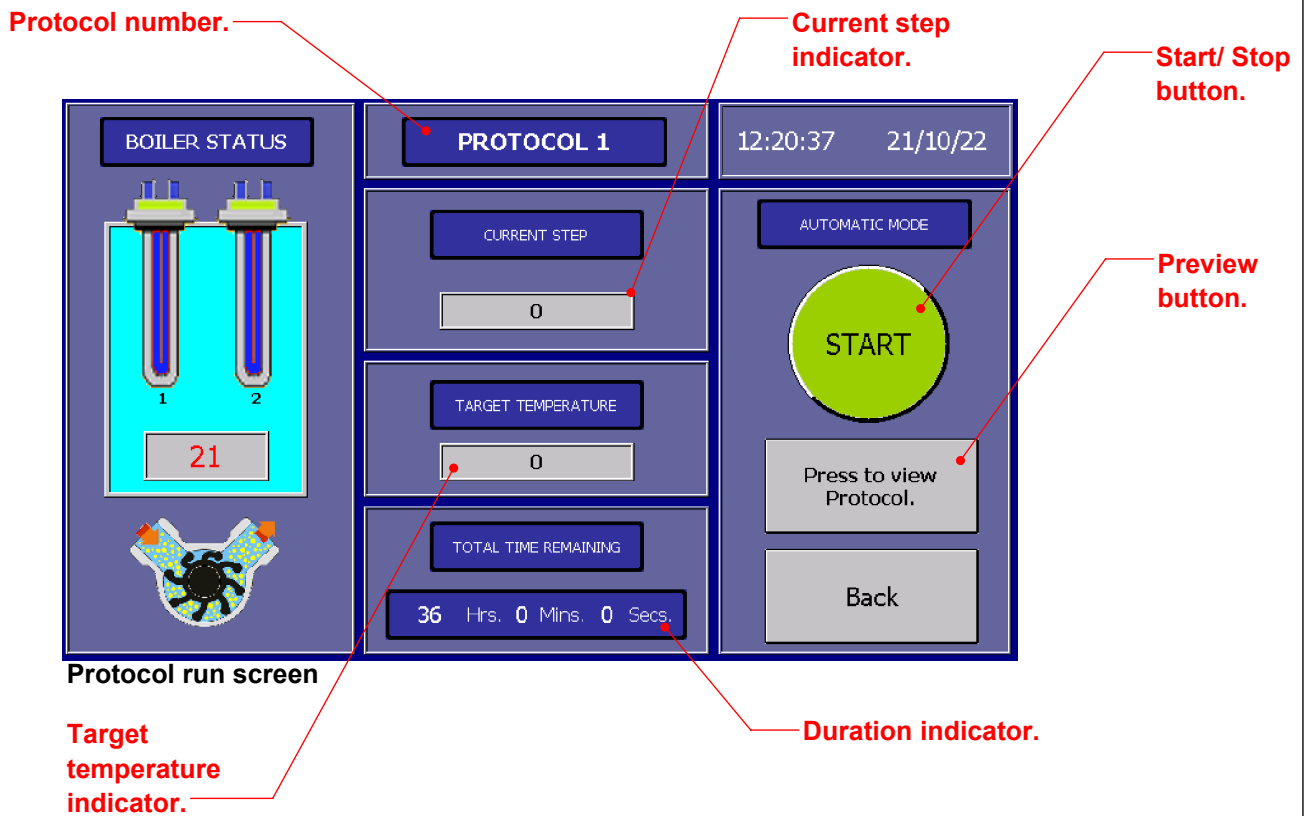

5: Once the appropriate protocol has been selected press the start button. The heating program will now start. The program will run through all of the steps and then heating will shut down. The circulation pump will continue to run. (If ECO mode is off).

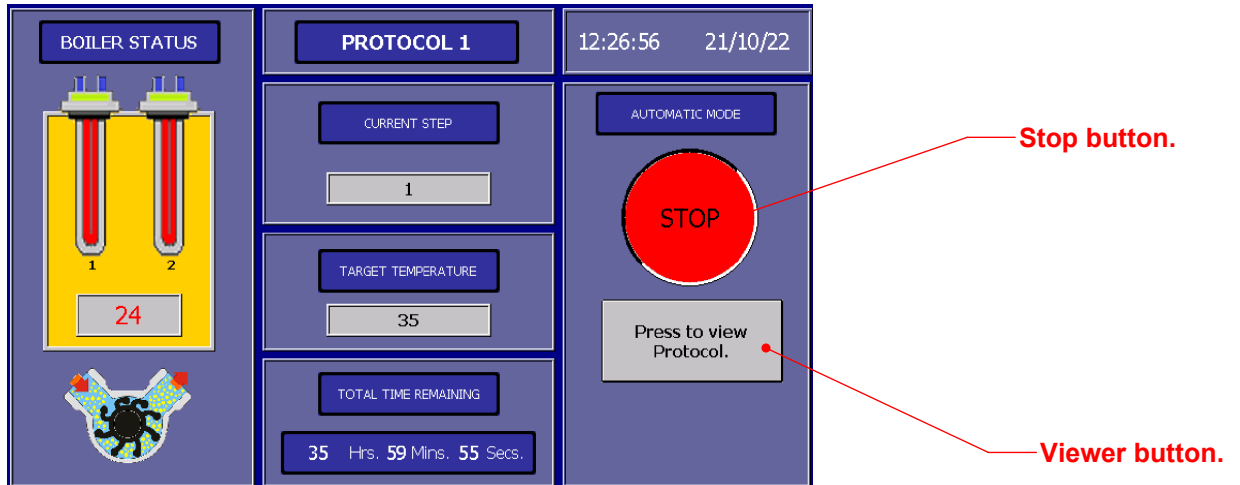

**Current step indicator:** The step indicator displays the current step of the protocol.

**Duration indicator:** This displays the amount of time the protocol has remaining.

**Target temperature indicator:** This displays the set point for the current program step.

The protocol can be viewed at any time during the process.  
Press the viewer button to go to the viewer screen.



## Frost protection:

The frost protection option is designed to prevent the machine from freezing at low ambient temperatures when not running a heating operation.

The machine must be powered and in standby mode for frost protection to work.

With frost protection activated when the heat exchanger temperature drops to a pre-set level a single heating element will activate and raise the temperature of the boiler up to a safe level before powering off again. The circulation pump will not run during a frost protection cycle.

This setting can be changed in the settings menu. (See P24). It is factory set at 2°C.

1: To activate frost protection navigate the controller to the home screen.

Home screen.

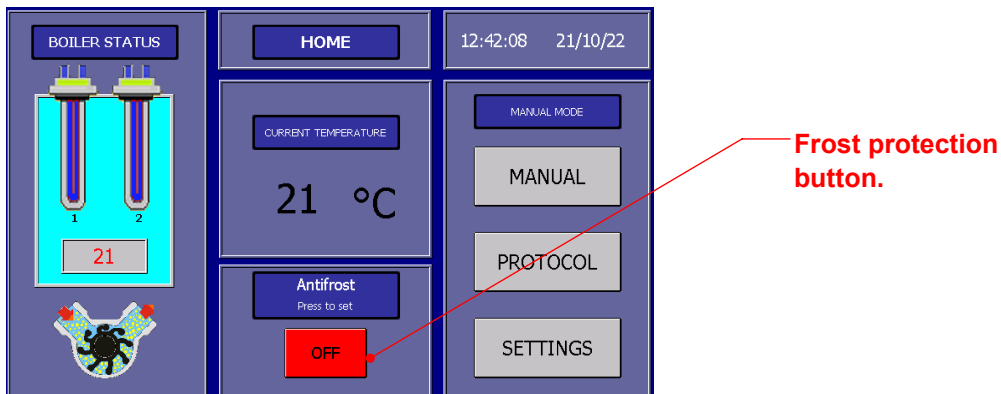

2: Press the frost protection button. The button will turn green to indicate it is on.

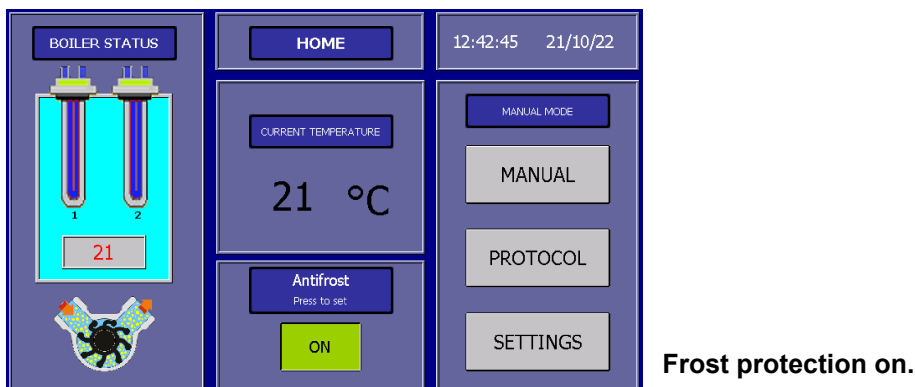

## Machine settings:

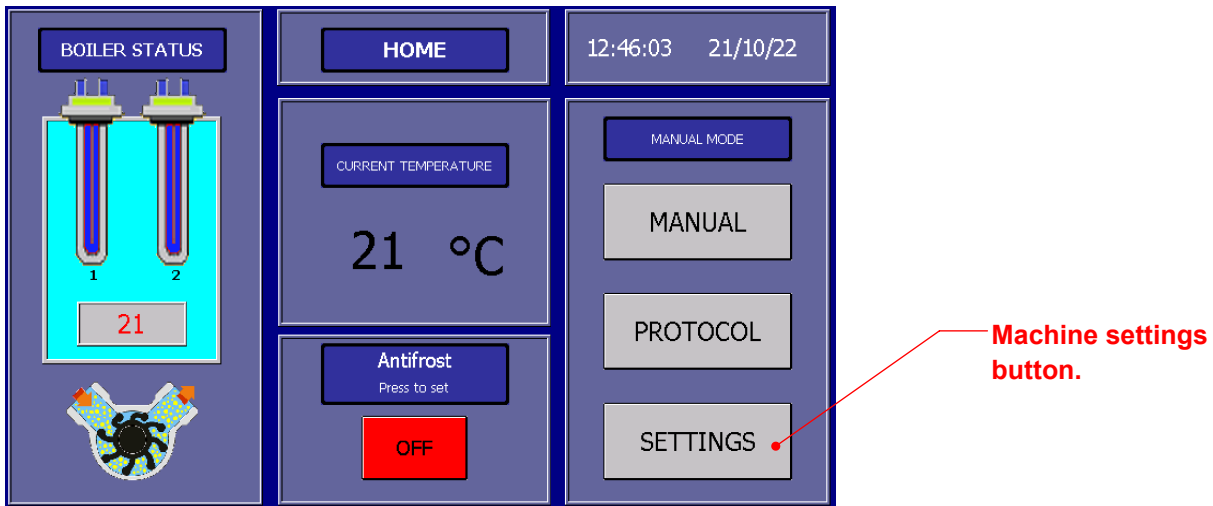

Home screen

A number of machine settings can be altered in the settings menu. These include:

- Password edit.
- Screen settings.
- Time/Date settings.
- Trim adjustment.
- ECO mode.
- Password protection on/off.

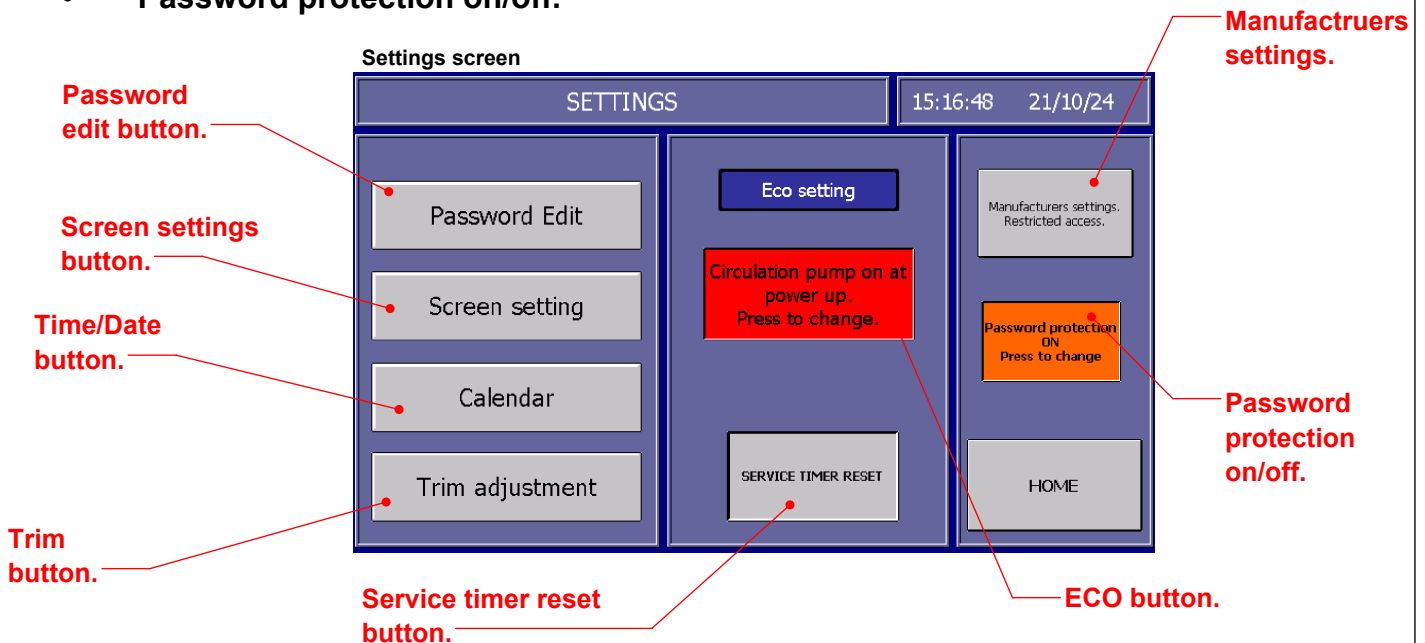

- 1: To access the Machine settings navigate to the Home screen and press the settings button.
- 2: You will be prompted for the password. (See P14).(A password is always required to access the settings).
- 3: Having entered the password you will be taken to the Settings screen.

## Machine settings cont'd:

### Password edit:

The User Password can be changed. Care will need to be taken to ensure that the new password is recorded. Should the new password be forgotten access to the control system will be prevented! Should this occur contact the manufacturer.

The factory set User Password is 1234.

Password edit screen.

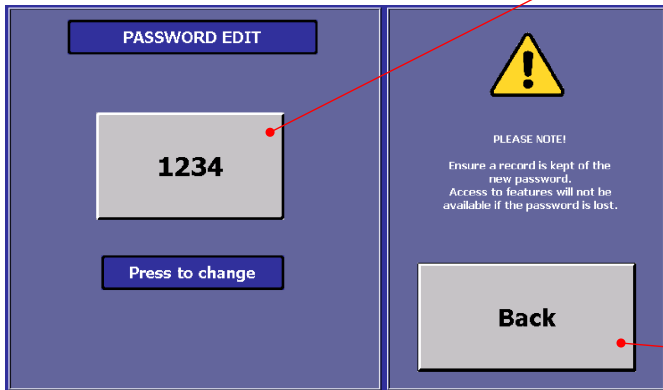

Change password button.



Back button.

1: Press the Password edit button on the settings screen. The Password edit screen will appear.

2: Press the Change password button. A key pad will appear.

3: Enter the new password (4 digits) and press OK. The new password will be saved.

### Trim:

This controls the point at which the heating contactors de-activate before the setpoint. This has a minimum of 0 degrees and a maximum of 5 degrees. Separate trims control each heating element.

### Service timer reset:

The service timer is programmed to activate after 1000 hrs of operation. Following a service this timer can be reset with this button.

### Screen settings:

The screen contrast and brightness can be changed by selecting this option.

### Manufacturers settings:

These are the manufacturers use only.

### Password protection on/off:

This button toggles password protection on or off.

When password protection is off a warning appears on the Home screen and the 'Manual' and 'Protocol' buttons turn orange.

Please note! A password is always required to access the settings screen.

## Time and date settings:

To change the time or date setting:

1: Navigate to the settings screen (See P25).

### Settings screen.

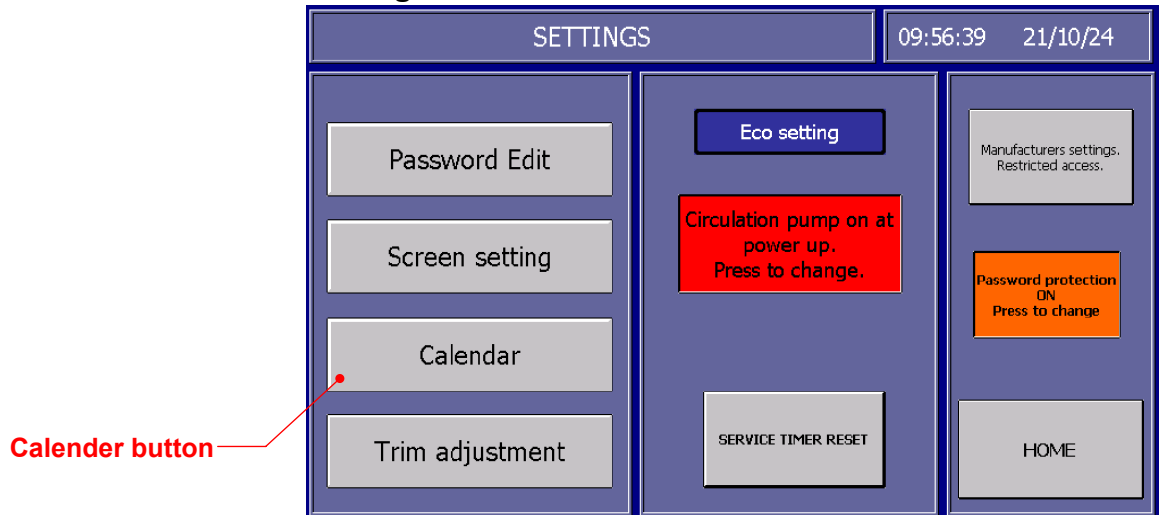

2: Press the Calendar button. This will take you to the Calendar screen.

### Calendar screen.

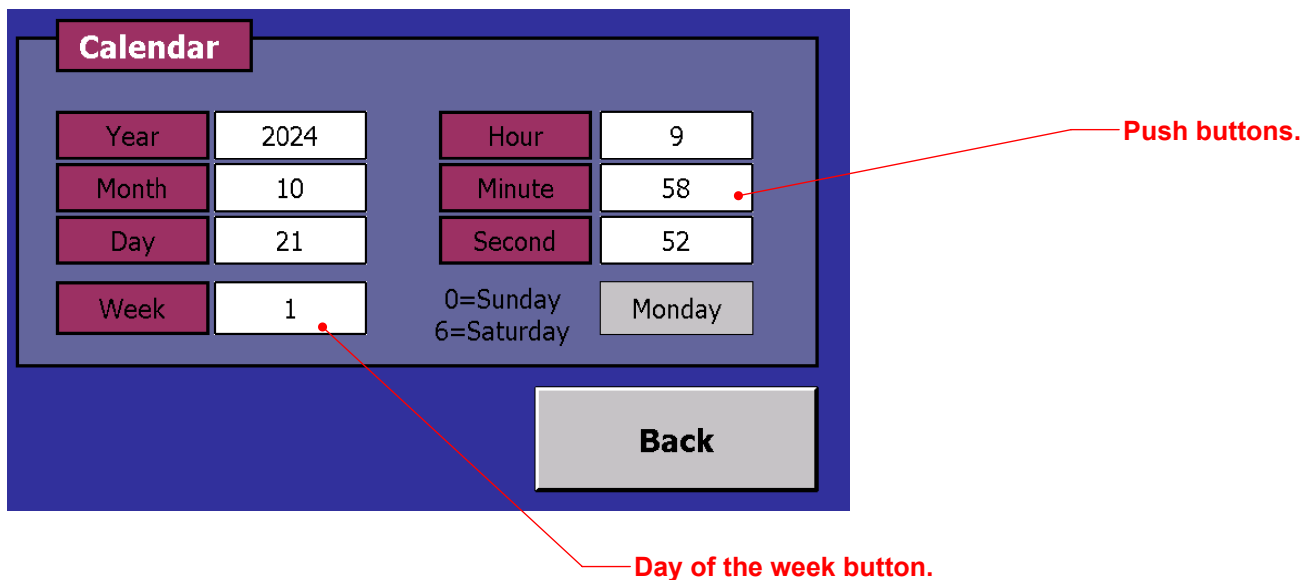

3: Press the white push-buttons to change any required settings.

4: To change the day of the week press the Day of the week button. The days of the week are represented by single digit numbers. Sunday being '0' and Monday being '1' etc.

5: Press the back button when changes are complete.

## Warning screens:

### Low water pressure/ Over-temperature fault screen.

THE BOILER WILL NOT OPERATE WITH THIS FAULT.

1: SWITCH OFF AND DISCONNECT MACHINE FROM POWER SUPPLY.

2: CHECK THE MACHINE FOR THE FAULTS LISTED BELOW.

3: RECTIFY THE FAULT.

4: RECONNECT TO THE POWER SUPPLY AND SWITCH ON.

5: PRESS THE RESET BUTTON.  
The program will continue from the point it stopped.

1: LOW WATER PRESSURE.  
Check the water pressure gauge.  
Top system water up to a minimum  
of 1.5 bar.  
(See manual).

2: HIGH TEMPERATURE ALARM.  
Check if the safety limit thermostat  
has activated.  
(See manual).

**ALARM !**

**RESET**

This fault screen indicates that either the water pressure is too low (below 1.5bar) or the over-temperature safety thermostat has activated.

The circulation pump and heating elements will switch off during these faults.

Switch the machine off and disconnect from the power supply.

Locate the fault and rectify.

- a) Low water pressure. Fill the system to between 1.5 and 2 bar.
- b) Over-temperature. Check the safety thermostat button(See P11). If this has activated the cause must be investigated. Allow the machine to cool and reset the over-temperature switch.

Once the fault has been rectified power on the machine and press the reset button on the fault screen.

## Warning screens cont'd:

### PT100 temperature probe fault screen.

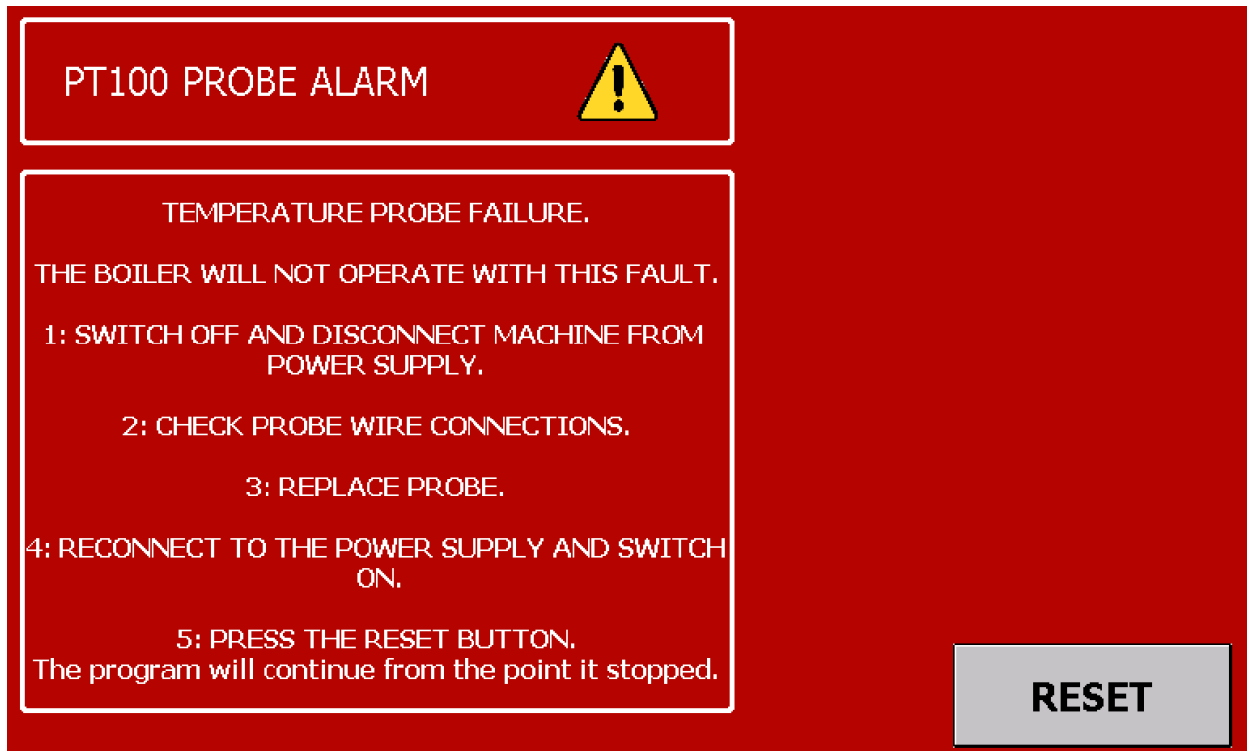

The image shows a red warning screen for a PT100 temperature probe fault. At the top left, a white-bordered box contains the text "PT100 PROBE ALARM" and a yellow warning triangle icon with a black exclamation mark. Below this, a larger white-bordered box contains the following text: "TEMPERATURE PROBE FAILURE.", "THE BOILER WILL NOT OPERATE WITH THIS FAULT.", "1: SWITCH OFF AND DISCONNECT MACHINE FROM POWER SUPPLY.", "2: CHECK PROBE WIRE CONNECTIONS.", "3: REPLACE PROBE.", "4: RECONNECT TO THE POWER SUPPLY AND SWITCH ON.", "5: PRESS THE RESET BUTTON.", "The program will continue from the point it stopped." To the right of this box, at the bottom of the red screen, is a grey rectangular button with the word "RESET" in black capital letters.

The WB22/36 control system is fitted with a PT100 temperature probe. In the event of a probe failure the heating elements and circulation pump will shut down and an error message will appear on the screen.

In the event of a probe failure error switch the machine off and disconnect from the power supply.  
Check all connections to the probe. Check the probe cable for damage. Replace the probe.

When the fault has been rectified power the machine on and press the reset button.

## **Boiler cleaning and maintenance:**

**Always ensure that the appliance is disconnected from the power supply before carrying out any work. Ensure the boiler has cooled fully before attempting maintenance or cleaning.**

### **Cleaning:**

- 1: Any dust and debris can be removed from the inside of the machine casing using compressed air. Safety goggles should be worn during this procedure.**
- 2: The machine casing can be wiped down with a moist cloth and mild detergent.**
- 3: Periodically rinse out the main heat exchanger by flushing through with clean water. This can greatly improve the performance of the boiler and extend the life of the pump.**

### **General maintenance:**

**Maintenance should only be carried out by skilled engineers familiar with the appliance.**

- 1: Periodically inspect the power cable and internal machine cables for signs of damage. replace where necessary.**
- 2: periodically inspect all electrical terminals and tighten where required.**
- 3: check the correct operation of the pressure relief valve before each installation (See P11).**
- 4: Every 1000 hrs of operation check the function of the low pressure switch. This can be achieved by draining the boiler, disconnecting the power cable to the circulation pump and attempting to start the boiler. The low pressure warning screen should illuminate. If faulty, switch off immediately and replace the switch.**
- 5: Regularly check all fixings are secure. Tighten where necessary. Do not operate the machine with missing fixings.**

## Fault finding:

**DO NOT ATTEMPT TO CARRY OUT RECTIFICATION WORK UNLESS THE APPLIANCE HAS BEEN ISOLATED FROM THE POWER SUPPLY!  
ENSURE CORRECT ISOLATION PROCEDURES ARE FOLLOWED AT ALL TIMES.**

<b>FAULT</b>	<b>POSSIBLE CAUSE</b>	<b>SOLUTION</b>
BOILER FAILS TO START. FAULT SCREENS NOT ILLUMINATED.	UNIT NOT SWITCHED ON	GO THROUGH START SEQUENCE.
	INTERNAL MCB TRIPPED	RESET MCB. INVESTIGATE CAUSE OF TRIPPING.
	FAULTY POWER SUPPLY	CHECK POWER SUPPLY AND RECTIFY.
BOILER FAILS TO START. CONTROLLER FAULT SCREEN ILLUMINATED.	WATER PRESSURE LOW	CHECK WATER PRESSURE IS BETWEEN 1.5 AND 2 bar. TOP SYSTEM UP AND RESTART.
BOILER FAILS TO START. CONTROLLER FAULT SCREEN ILLUMINATED. OVER-TEMPERATURE SWITCH HAS ACTIVATED..	SAFETY LIMIT THERMOSTAT ACTIVATED. EXCESSIVE TEMPERATURE.	RESET THE SAFETY THERMOSTAT. INVESTIGATE THE CAUSE OF TRIPPING. IT SHOULD BE NOTED THAT IT CAN TAKE A SIGNIFICANT TIME FOR THE THERMOSTAT TO COOL SUFFICIENTLY TO RESET. IF THE PROBLEM PERSISTS CONTACT SUPPLIER.
BOILER RUNNING NORMALLY. NO HEATING AT RADIATORS OR HEATING OUTLETS.	INLET OR OUTLET VALVES CLOSED.	RECTIFY AND RESTART
INSUFFICIENT TEMPERATURE RISE AT RADIATORS OR HEATING OUTLETS.	CONTROLLER SET POINT TOO LOW.	RESET TO THE DESIRED TEMPERATURE.
	SYSTEM TOO LARGE FOR THE CAPACITY OF THE BOILER.	CONTACT SUPPLIER.

# Spare parts:

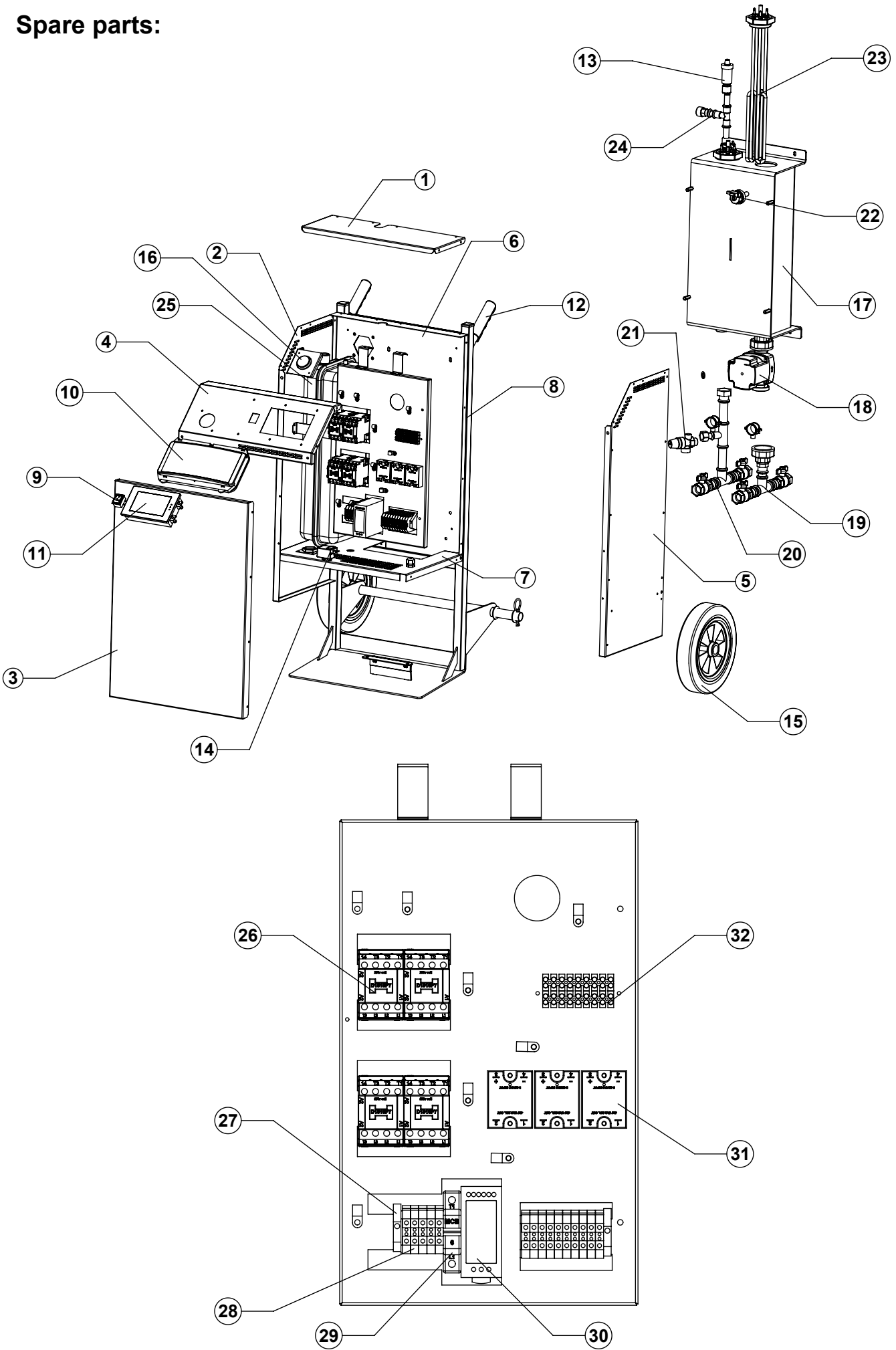

**Spare parts:**

**Rear heat exchanger.(Optional)**

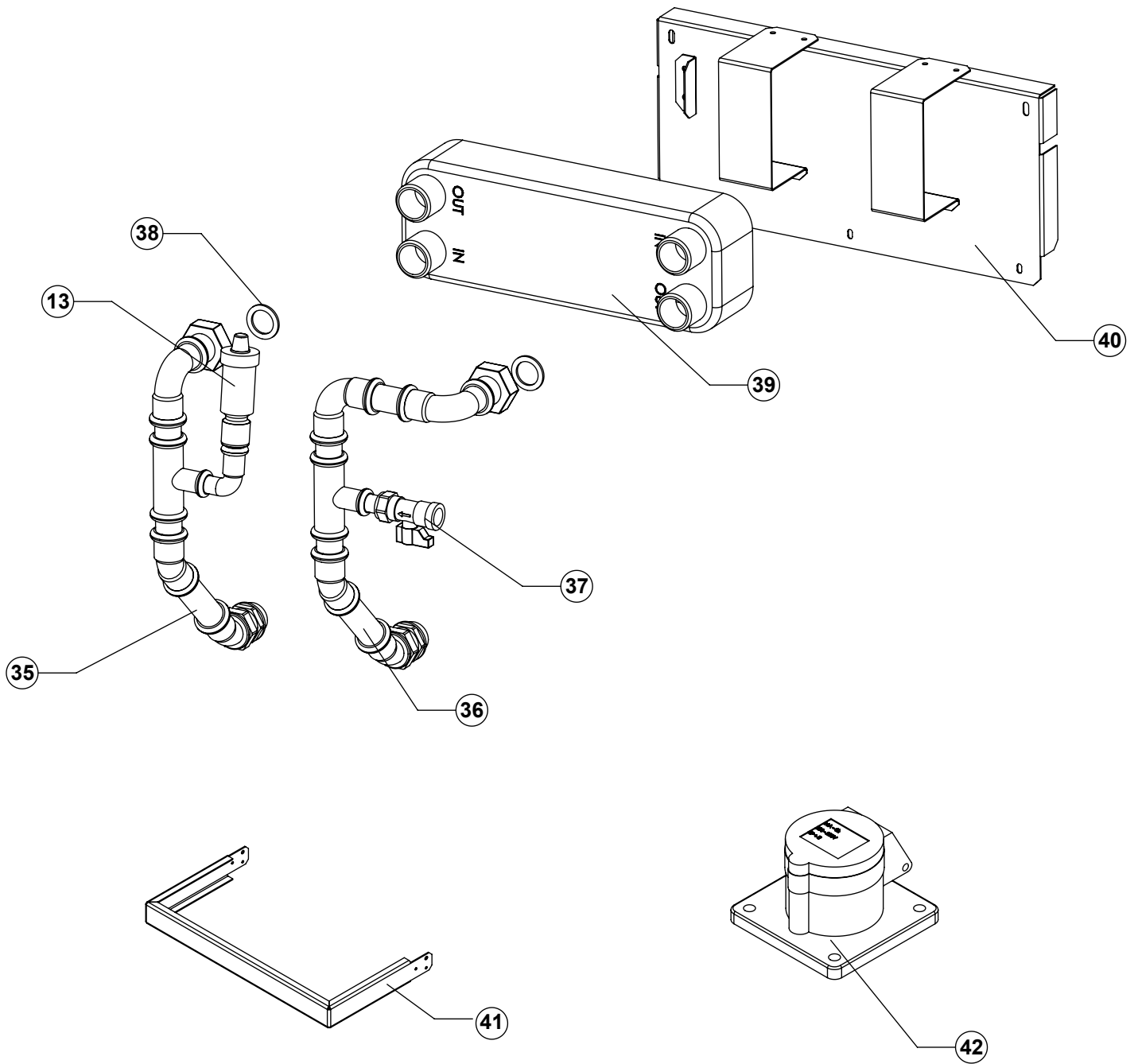

## Spare parts:

Drawing No	Description	Part No
1.	Top panel	BW010223
2.	Left side panel	BW010416
3.	Front panel	BW010631
4.	Control panel	BW010632
5.	Right side panel	BW010323
6.	Rear panel	BW010717
7.	Galvanised metalwork set.	BW020913
8.	Welded trolley frame.	BW020912
9.	0/1 Rocker switch.	EL030135
10.	Inspection window	EL040134
11.	PLC controller	EL040138
12.	Rubber handle grip	ME040431
13.	Automatic air bleed.(Push-fit).	ME0401187
14.	Safety limit thermostat. SPDT.	EL030415
15.	250mm wheel.	ME010106
16.	Pressure gauge. (White)	ME040531
17.	Welded heat exchanger	BW020914
18.	Circulation pump.	ME040197
19.	Inlet manifold assembly	BW040425
20.	Outlet manifold assembly	BW040426
21.	Pressure relief valve.	ME0401188
22.	Low pressure switch.	EL030161
23.	Heating element. 10.5kW.(WB22 only)	HE010116
23.	Heating element. 18kW. (WB36 only)	HE010124
24.	Expansion tank manifold assembly.	BW040427
25.	Expansion tank. 10ltr	ME0401111
26.	Contact. 18/32A. 230v coil. (WB22 only).	EL030814
26.	Contact. 18/32A. 230v coil. (WB36 only).	EL010239
27.	DIN mounted end stop.	EL020403
28.	6mm terminal.	EL020413
29.	MCB. 6A. Single pole. Type C.	EL010222
30.	Power supply unit. 230VAC-24DC	EL040139
31.	Solid state relay. 25A. 24VDC.	EL030214
32.	Plug-in terminal.	EL020450
33.	Power-lead with plug. 32A 3p+N+E (WB22 only). (Not shown).	EL020133
33.	Power-lead with plug. 63A 3p+N+E (WB36 only). (Not shown).	EL020143
34.	PG21 Cable gland with lock-nut. (Not shown).	ME040204
35.	Heat exchanger inlet manifold. (Optional).	BW040428
36.	Heat exchanger outlet manifold. (Optional).	BW040429
37.	Isolating valve. 15mm. (Optional).	ME0401151
38.	1" Fibre washer. (Optional).	FI060411
39.	Plate heat exchanger. (Optional).	FR030217
40.	Heat exchanger metalwork set. (WB22 only). (Optional).	BW040528
40.	Heat exchanger metalwork set. (WB36 only). (Optional).	BW020915
41.	Protective rear heat exchanger bar. (Optional).	BW040529
42.	Power outlet socket. 230v. (Optional).	EL020528
43.	16mm Terminal. (WB36 only)	EL020438

# Wiring diagrams:

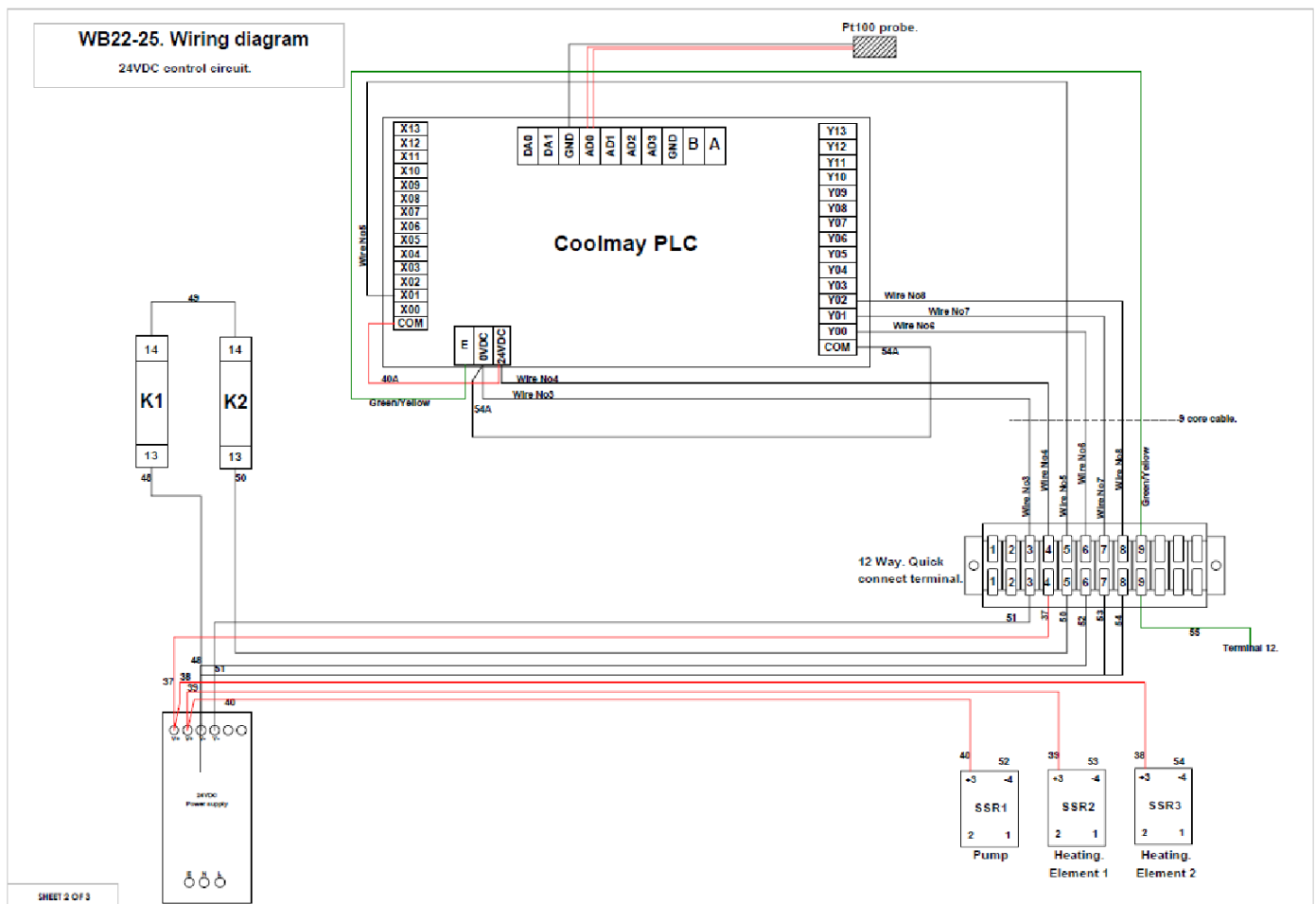
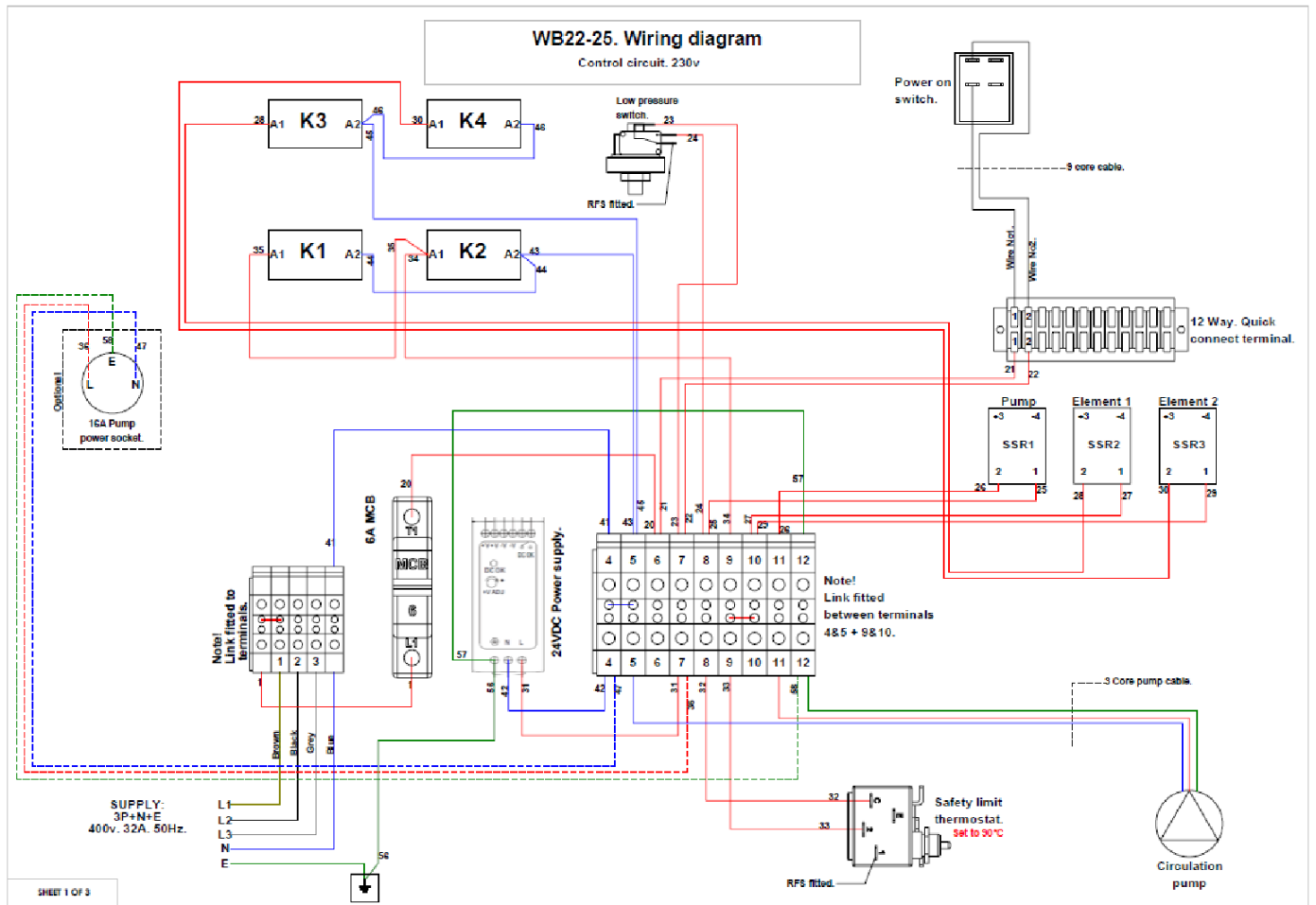

# Wiring diagrams:

## WB22-25. Wiring diagram

Power circuit

10.5Kw ELEMENT CLUSTER No1

10.5Kw ELEMENT CLUSTER No2

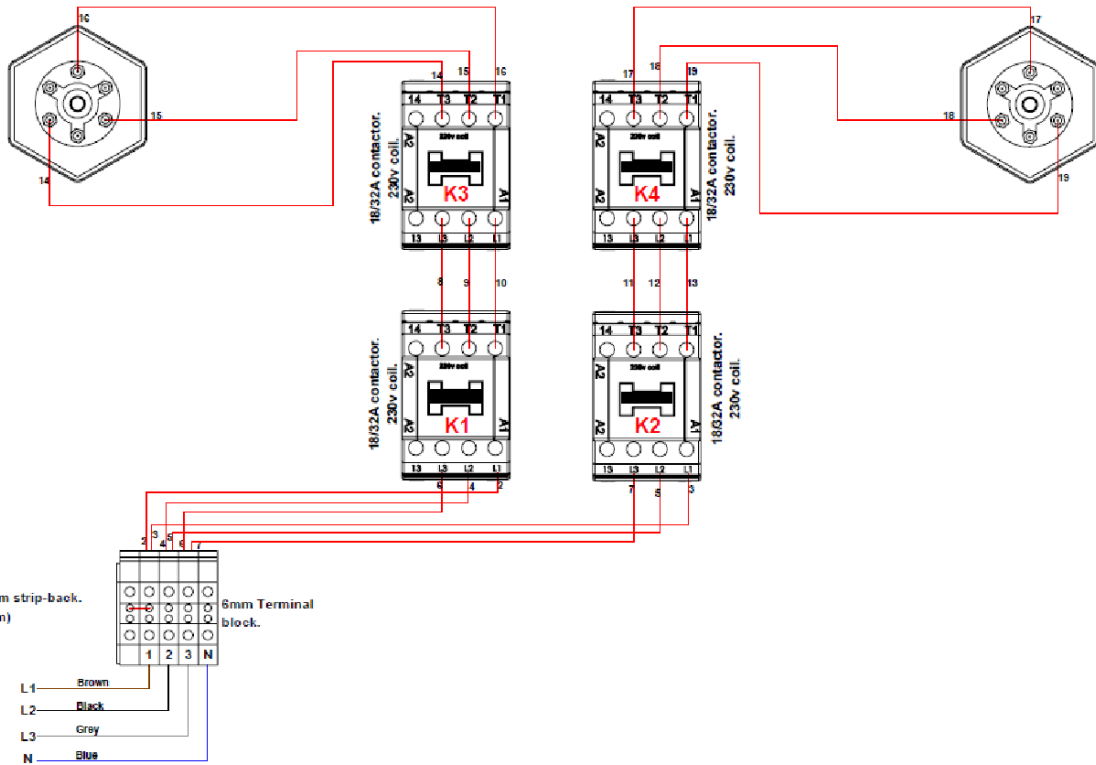

SHEET 3 OF 3

# Wiring diagrams:

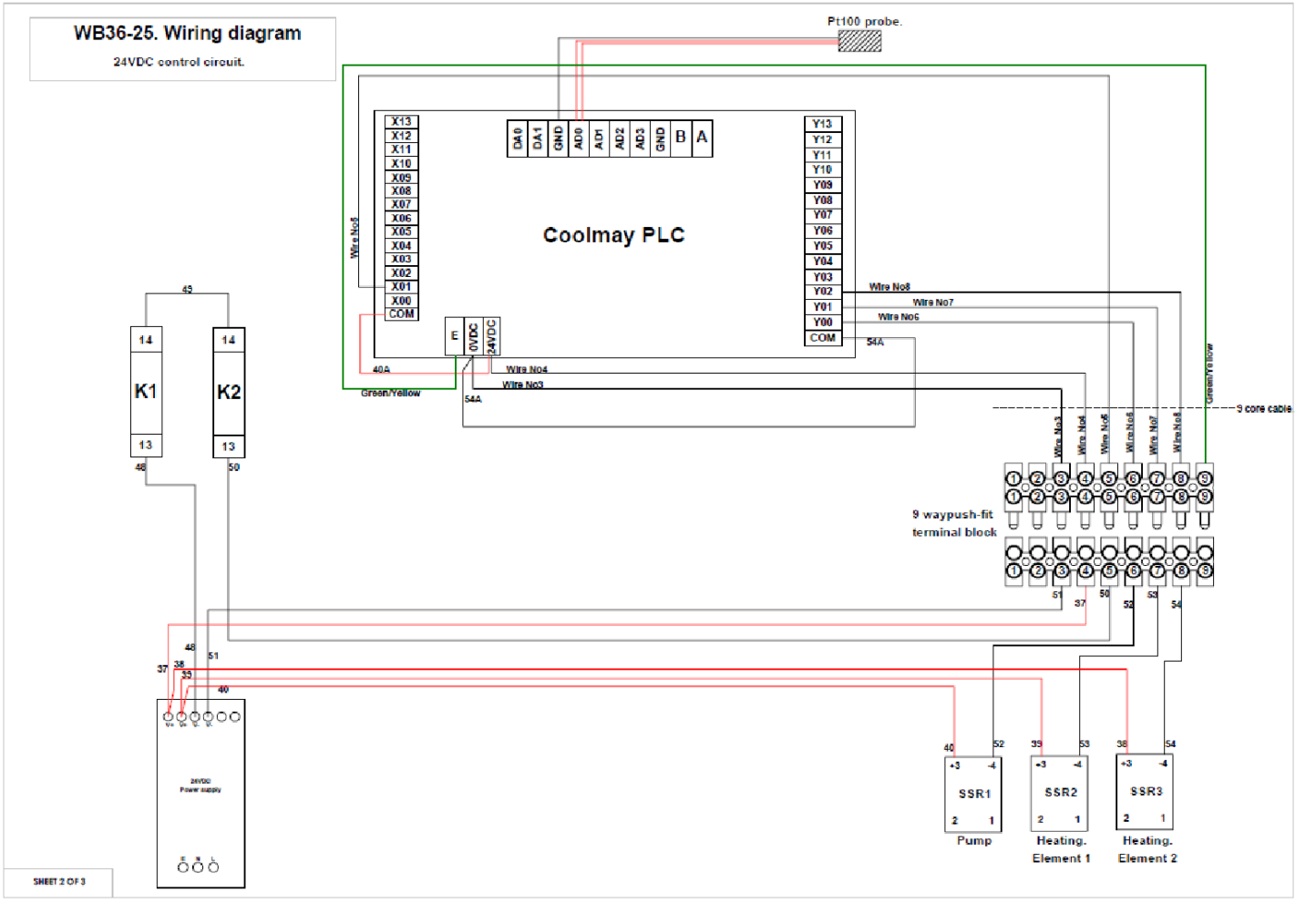
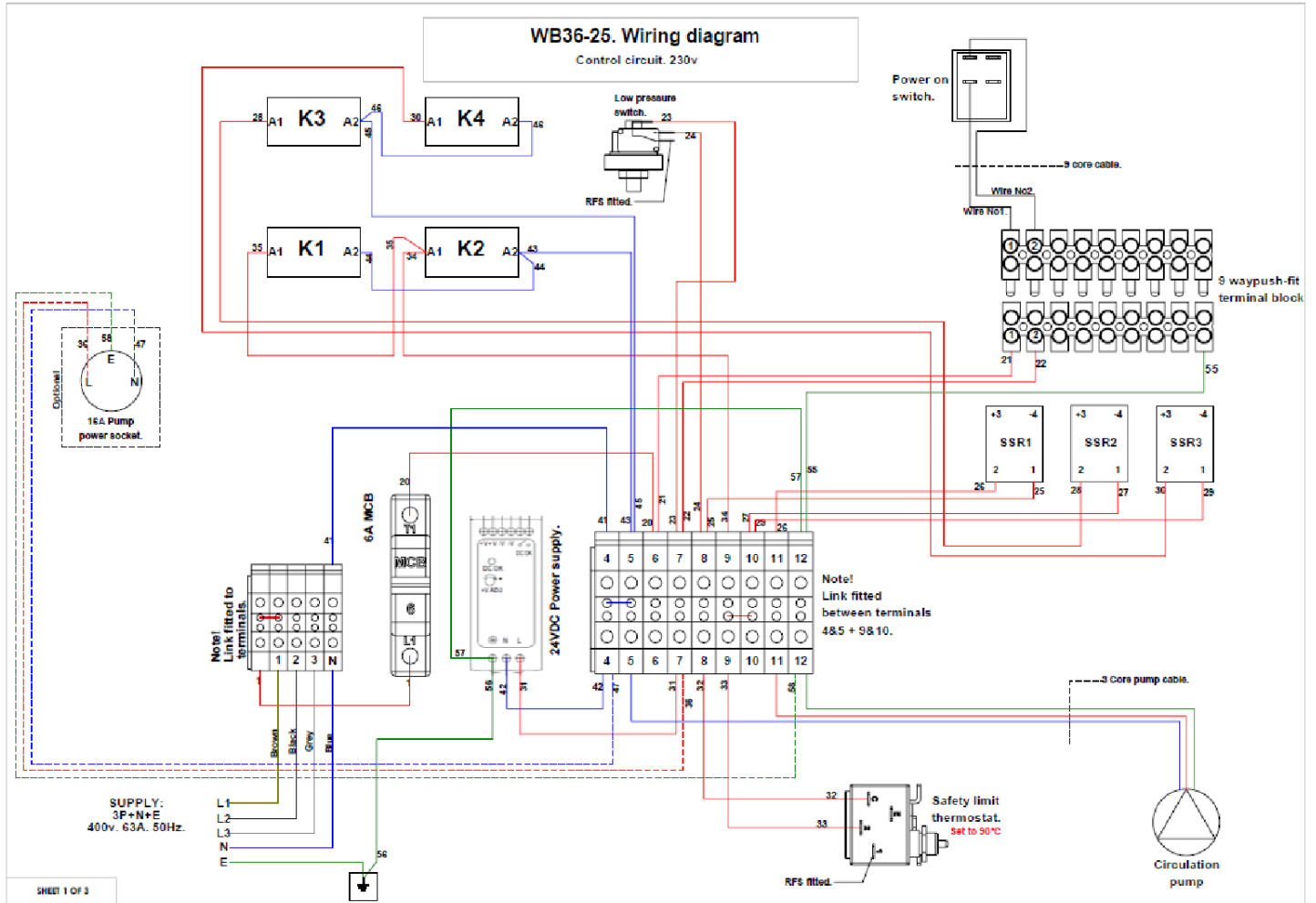

# Wiring diagrams:

## WB36-25. Wiring diagram

Power circuit

18Kw ELEMENT CLUSTER No1

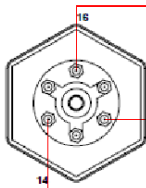

18Kw ELEMENT CLUSTER No2

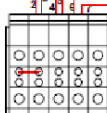
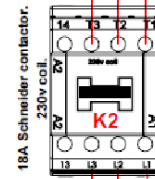
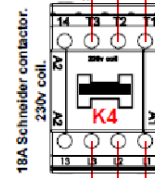
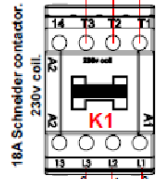
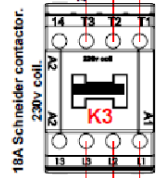
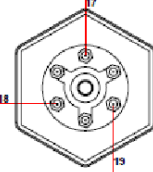

Double ferrule= 20mm strip-back.  
RS: 178-8746 (2x4mm)

6mm Terminal block.

SUPPLY:  
3P+N+E.  
400v. 63A. 50Hz.

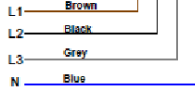

SHEET 3 OF 3

## Pump settings and fault codes:

### WB22-25B/ WB36-25. Stream pump.

#### Settings:



The pump should be set at fixed speed. Speed 3.

#### Fault codes:



Blinking lamp indicates a fault with the pump power supply.



Blinking lamp indicates high pump current.



Blinking lamp indicates system low on water.



Blinking lamp indicates blocked pump.



3 Blinking lamps indicate pump windings are overtemperature.